

# VTGA SERIES

200 PSI BSP

316 STAINLESS STEEL GATE VALVE



## ADVANTAGES

- ▷ Quality Investment casting body.
- ▷ Stainless steel class 200 inside screw & screwed bonnet.
- ▷ Wedge disc integral seat, non-rising stem & handwheel.



## TECHNICAL DATA

Size Range	DN15 - DN80 (1/2" - 3")
Pressure Rating at 20°C	200 PSI W.O.G.
Connection	BSPP

# VTGA SERIES

200 PSI BSP

## MATERIAL SPECIFICATIONS & PARTS LIST

NO.	DESCRIPTION	MATERIAL
1	Body	CF8M
2	Disc	CF8M
3	Bonnet	CF8M
4	Gasket	PTFE
5	Bush	SS304
6	Packing	PTFE

NO.	DESCRIPTION	MATERIAL
7	Gland	SS304
8	Cap Nut	CF8M
9	Stem	SS316
10	Handle	Aluminium
11	Nameplate	Aluminium
12	Stem Nut	SS304

## DIMENSIONAL DRAWING

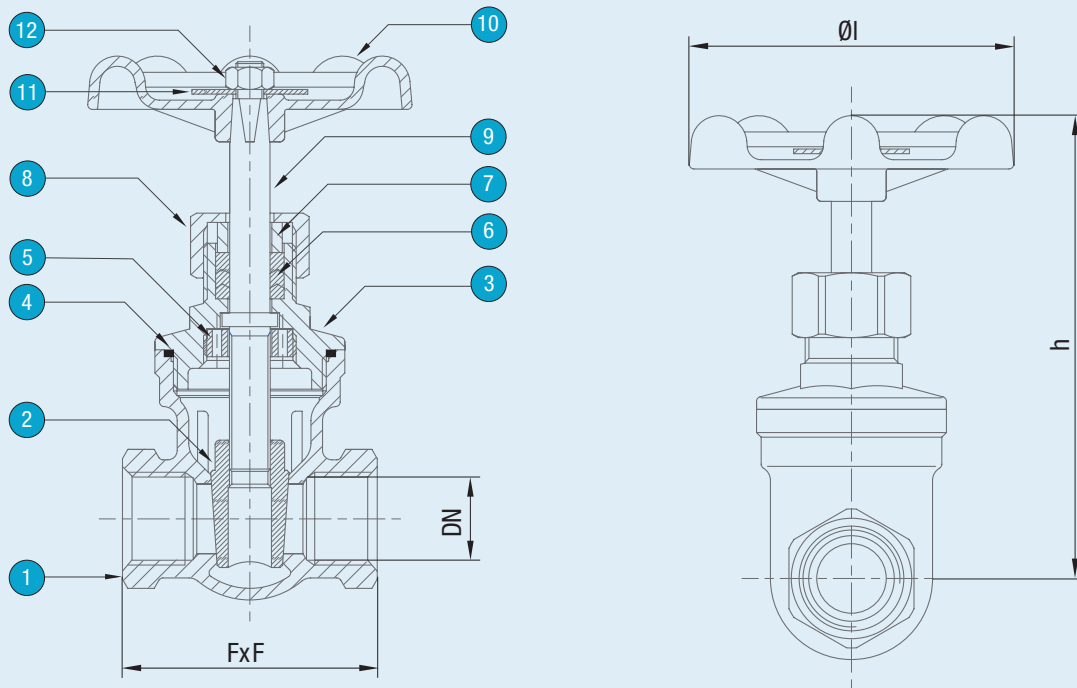

## DIMENSIONS (MM)

VTGA SERIES DN15-DN80						
DN	NPS	FxF	h	ØI	CV Factor	WEIGHT (KG)
15	1/2"	55	101	70	17.6	0.42
20	3/4"	50	108	70	32	0.52
25	1"	65	120	80	54	0.70
32	1 1/4"	75	132	80	97	1.01
40	1 1/2"	85	149	90	135	1.54
50	2"	95	175	100	230	2.06
65	2 1/2"	116	213	140	337	5.56
80	3"	130	241	140	455	8.63

## PRESSURE RATINGS

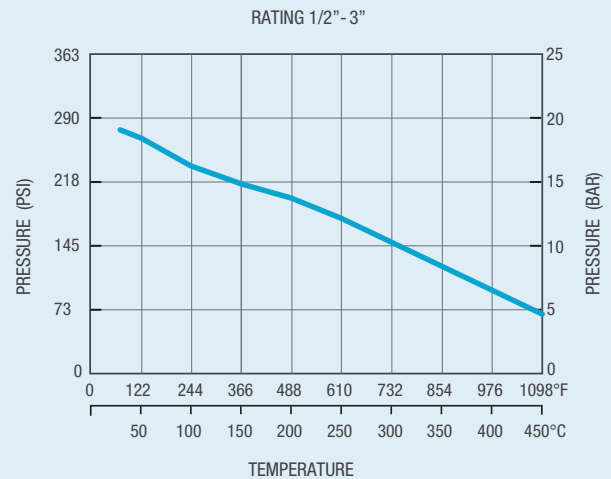

54 Enterprise Drive, Bundoora, VIC, 3083  
 p. 1300 789 256 | e. sales@avfi.com.au  
 avfi.com.au

Designs, material and specifications shown are subject to change without notice due to our continuing program of product development.

All content is protected by Copyright and is owned and/or licensed by AVFI Pty Ltd. Copyright © AVFI Pty Ltd

