

VTC SERIES

SWING CHECK VALVE

316 STAINLESS STEEL BSP, CLASS 200 PSI



ADVANTAGES

- ▷ Investment casting body.
- ▷ Stainless Steel.
- ▷ Full Port.
- ▷ Screwed Cap.
- ▷ Integral Seat



TECHNICAL DATA

| | |
|-------------------------|------------------------|
| Size Range | DN8 - DN80 (1/4" - 3") |
| Pressure Rating at 20°C | 200 PSI W.O.G. |
| Connection | BSPP |

VTC SERIES

SWING CHECK VALVE

MATERIAL SPECIFICATIONS & PARTS LIST

| NO. | DESCRIPTION | MATERIAL |
|-----|-------------|----------|
| 1 | Body | CF8M |
| 2 | Cap | CF8M |
| 3 | Gasket | PTFE |
| 4 | Plug | SUS316 |

| NO. | DESCRIPTION | MATERIAL |
|-----|-------------|----------|
| 5 | Disc | CF8M |
| 6 | Gasket | PTFE |
| 7 | Bolt | SUS304 |

DIMENSIONAL DRAWING

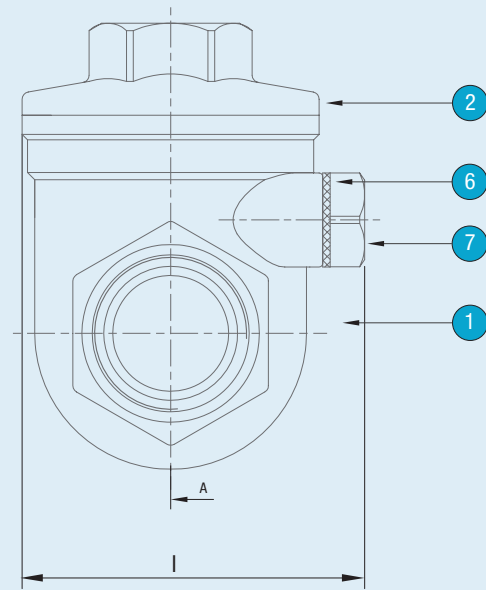
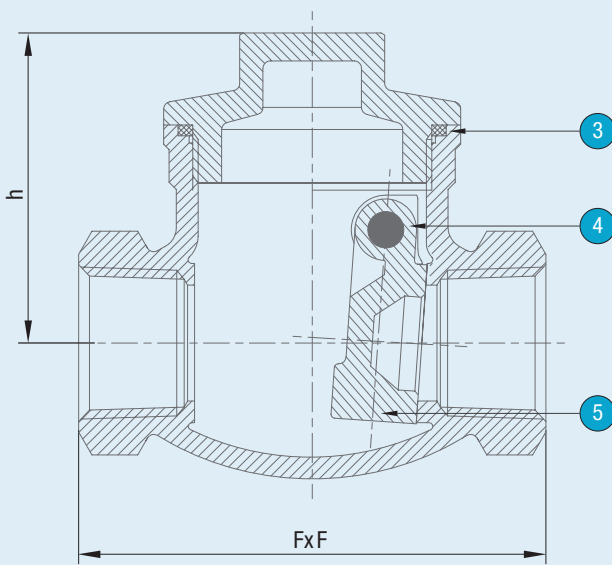

DIMENSIONS (MM)

| VTGL SERIES DN8-DN65 | | | | | |
|----------------------|--------|-----|-----|------|-------------|
| DN | NPS | FxF | h | I | WEIGHT (KG) |
| 8 | 1/4" | 65 | 43 | 46.5 | 0.36 |
| 10 | 3/8" | 65 | 43 | 46.5 | 0.36 |
| 15 | 1/2" | 65 | 43 | 48 | 0.36 |
| 20 | 3/4" | 80 | 54 | 51.5 | 0.43 |
| 25 | 1" | 89 | 60 | 56 | 0.66 |
| 32 | 1 1/4" | 105 | 66 | 64 | 0.93 |
| 40 | 1 1/2" | 120 | 75 | 76 | 1.49 |
| 50 | 2" | 139 | 80 | 84 | 2.15 |
| 65 | 2 1/2" | 181 | 99 | 105 | 5.27 |
| 80 | 3" | 200 | 104 | 140 | 7.70 |

PRESSURE RATINGS

