

Electric Actuators and Control Systems

rotork® Controls

Established Leaders in Valve Actuation



IQ Pro Range

**IQ and IQT Multi-turn and Quarter-turn
Electric Valve Actuators**



Rotork actuators have been in use all around the world for over 50 years. In this time Rotork has grown to become the leader in the valve automation industry. With manufacturing, service centres, offices and representatives throughout the world, Rotork is able to offer global service solutions to your company.

In the 50 years since the company was founded, Rotork has become a byword for excellence in the field of valve, sluice gate and damper actuation products for the oil, gas, power, water and waste treatment industries - worldwide.

We owe our success to an uncompromising focus on quality at every stage - and at every level - of Rotork's operations.

From initial site survey, specification and design, through to materials, manufacturing and testing, installation, commissioning and after-sales service we accept nothing but the best.

At the heart of the company is an exceptional workforce - the highly trained, forward-thinking engineers, technicians and support staff who each have a crucial role to play in maintaining Rotork's unrivalled reputation for innovation, reliability and first class customer support.

The Rotork family of products also includes pneumatic, hydraulic and electro-hydraulic actuators as well as a comprehensive range of gearboxes and valve accessories. Rotork's bespoke Pakscan digital control system offers market leading features whilst all our actuators offer the ability to interface with other digital control systems.

Rotork. Established leaders in valve actuation technology.

rotork®
Controls

rotork®
Fluid Systems

rotork®
Gears

rotork®
Site Services

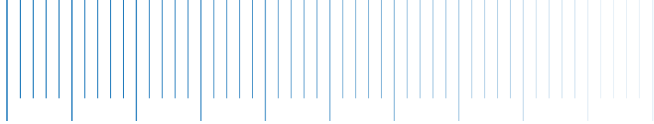

Contents

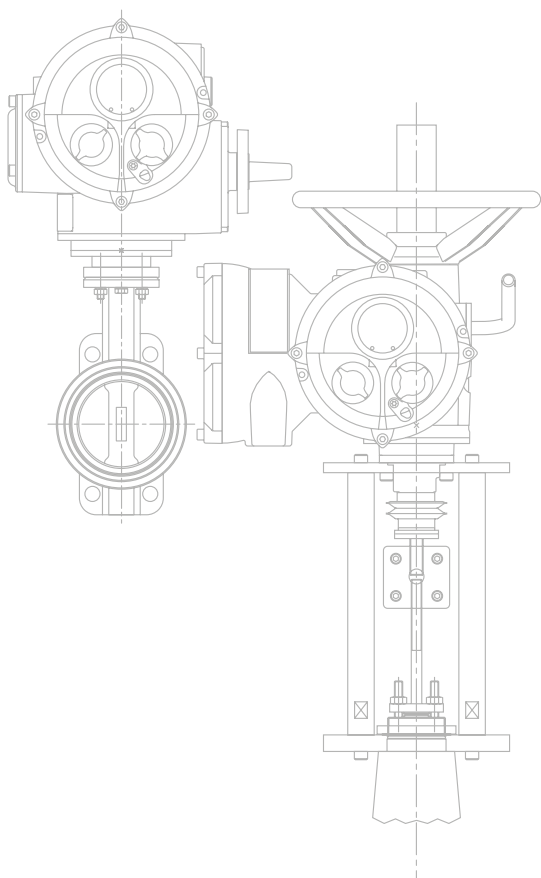

This brochure provides a comprehensive overview of the applications and associated functions available with Rotork IQ Pro actuators - comprising IQ multi-turn and IQT quarter-turn ranges.

For information about IQ actuators and explanation of their features see Section 1. For detailed technical specifications and performance data see Section 2.

Launched in 1993, the IQ actuator was the first 'intelligent' non-intrusive actuator available to the valve market. It introduced revolutionary features including the data logging of actuator operation history and an infra-red setting tool replacing traditional mechanical setup.

In 2000 the IQ received a major upgrade with additional control and monitoring features, datalogging, piezo torque measurement technology, improvements in user interface, ergonomics and, corrosion resistance.

The IQT quarter-turn actuator was launched in 2004, encompassing all of the intelligent features of the IQ in a direct quarter-turn actuator.

Section 1

IQ range actuators	4
IQT range actuators	5
<i>Pro</i> Features	6
Advanced Engineering	8
Design Features	10
Reliability	10
Protection	11
Intelligent Communication	12
Customising	13
Pakscan Bus Control System	14
Multiple Bus Connectivity	16
Rotork Site Services	18

Section 2

Actuator Specification (full contents list on p21)	21
Performance Summaries	22
Actuator Drive Couplings	28
Standard Specification	30

Building on previous developments, IQ Pro brings together IQ and IQT ranges within a single integrated approach with additional common enhancements. These include multilingual text displays that can be uploaded without restriction (other than translation) and currently include Spanish, German, French, Chinese (Mandarin), and Russian. Downloadable of actuator configuration and data log files (using the supplied non-intrusive, intrinsically safe IQ Actuator Setting Tool *Pro*) allows comprehensive asset management and valve & actuator performance monitoring, using the free Windows™ operating system application IQ-Insight.



IQ multi-turn actuators



The IQ range

The Rotork IQ delivers a complete range of actuators suitable for all multi-turn valve applications requiring control and indication flexibility. It offers end users ever higher standards of performance, build quality and overall value.

Simple Commissioning

The Rotork IQ provides simple, safe and rapid non-intrusive commissioning with infra-red control. Actuator settings such as torque levels, position limits, control and indication functions can be accessed and adjusted using the "point and shoot" IQ Setting Tool *Pro*. This supplied, intrinsically safe (IS) tool is unique to Rotork and allows for non-intrusive actuator set-up whatever the environment, power on or off.

Simple Troubleshooting

The large digital position display clearly indicates real time valve position from a distance. In addition, active valve, control, actuator status and alarm text messages are displayed on the easy to read back-lit display. Using the IQ Setting Tool *Pro* real-time torque against position profiles and actuator configuration can be accessed during commissioning, adjustment or local valve performance monitoring. The onboard data logger records operational, alarm and valve torque profile data providing valuable information on valve and plant operating performance and conditions.

IQ offers a range of powerful features:

- Three phase, direct current and single phase actuators
- On-board data logger included as standard
- IrDA™ compatible for local and remote actuator analysis via InSight PC software
- Clear, user friendly controls and indication
- Multilingual text display for status and setup
- Simplified torque and position control for increased reliability
- Comprehensive control and flexibility
- Approved for use in SIL applications†

IQ

IQ actuators are multi-turn electric actuators which can be used for isolation or regulating duties of up to 60 starts per hour. IQ's are watertight or watertight and explosionproof depending upon specification.

Direct torque output range from 34 Nm (25 lbf ft) to 3,000 Nm (2,200 lbf ft).

IQM

The modulating version of the IQ has a solid state reversing starter in place of the electromechanical contactors. "Hammerblow" lost motion drive is removed and fast response remote control circuits for rapid control are included. The IQM is suitable for up to 1,200 starts per hour. The solid state starter also adds an electronic motor 'brake' feature, improving positional control.

IQML

Benefiting from all the features of the IQ and IQM actuators, the IQML has a linear output drive providing modulating thrust output of up to 150 kN.

IQS

IQS actuators are single phase versions of IQ actuators.

Torque range from 65 Nm (48 lbf ft) to 450 Nm (332 lbf ft).

IQD

IQD actuators are direct current (DC) versions of IQ actuators.

Torque range from 34 Nm (25 lbf ft) to 305 Nm (225 lbf ft).

IQH

The IQH provides a range of high output speeds while being generally irreversible and therefore providing a self-locking* ability by the actuator for the valve. Developed for diverter valves in meter prover applications, IQH provides fast operation with positive seating without backdriving.

*For detailed information see publication E118E

Special Designs

With our extensive product range and engineering knowledge Rotork can provide solutions for most applications.

†with an additional SFCM Control Module



The IQT range

The IQT (IQ quarter-turn) is the result of ongoing commitment to product development at the cutting edge of new technology.

Maintaining the simple commissioning and troubleshooting design of the Rotork IQ (see left), the new IQT introduces a direct drive, quarter turn actuator—offering the highest standards in comprehensive control, access to real time diagnostics and comprehensive bus compatibility.

IQT features:

- Direct drive quarter-turn
- Three phase, direct current and single phase actuators
- Multilingual text display for status and setup
- On-board data logger included as standard
- IrDA™ compatible for local and remote actuator analysis via InSight PC software
- Clear, user friendly controls and indication
- Simplified torque and position control for increased reliability
- Comprehensive control and flexibility
- Approved for use in SIL applications†

IQT

IQT actuators are direct drive quarter-turn electric actuators which can be used for isolation or regulating duties of up to 60 starts per hour. IQT's are watertight or water-tight and explosionproof depending upon specification.

Torque output from 50 Nm (37 lbf ft) to 2,000 Nm (1,476 lbf ft).

IQT Fail Safe

The IQT Failsafe actuator provides valve failsafe operation by utilising power from an internal battery during AC supply mains failure. Under normal supply conditions the actuator operates from the site AC electrical supply. On loss of this supply the actuator automatically switches over to receive power from a 24 V DC supply allowing control of the valve to the failsafe position.

For detailed information see publication E116E

IQTM

The modulating version of the IQT has solid state motor switching and includes fast response remote control circuits for rapid response to control signals. The IQTM is suitable for up to 1,200 starts per hour.

IQTF

The IQTF provides extended output rotation for part turn valve types requiring more than 90° for operation. Typical valves include 180° and 270° diverter valves and multipoint manifolds requiring bi-directional 360° operation. The IQTF actuator has a low output speed for increased positional accuracy.

The IQTF may also be utilised for low turn, multiturn applications where slow operation is required.

For detailed information see publication E119E

IQTN

The IQTN has been developed to meet the specialist demands of nautical & military applications within a standard package.

Retaining all the features of the IQT the IQTN has a shorter electronics cover for confined on-board spaces and an anti-shock base.

For detailed information see publication E1122E

Special Designs

With our extensive product range and engineering knowledge Rotork can provide solutions for all applications.

Pro

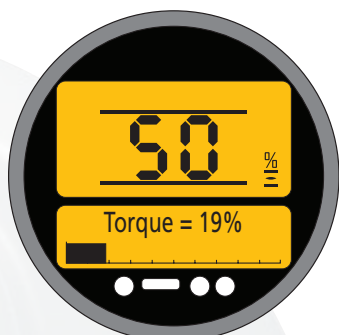

Torque and Position Monitoring



Realtime Monitoring



Actuator Alarms



Pro features

IQ Pro combines existing proven Rotork IQ features with additional control and indication functions, improved user interface design, performance monitoring and datalogging - including valve torque signature profiles. This means unparalleled support in achieving reliable valve actuation.

Founded on over 15 years of operational experience, the IQ Pro control system combines proven control logic with field programmable technology, thus providing increased functionality and reliability. IQ Pro control logic can be upgraded over the IrDA™ interface – this will “future proof” valve operation against control system and actuator developments and upgrades.

In combination with the new non-intrusive, Intrinsically Safe Rotork Setting Tool Pro, IQ actuator set-up and datalogger files can be transported from the field to the office for storage and analysis.

IQ and IQT Pro offer a range of powerful features unparalleled in Valve Actuation:

- Field upgradeable control system
- Larger, clearer display
- Customer configurable, multilingual text capability
- Datalogger valve torque signature profiling
- Status & monitoring diagnostics
- Retrofittable to existing IQ & IQT range of actuators (post 2000)
- Improved data download speed x 10

Setting Tool Pro features include:

- Non-intrusive, Infra-red communication
- Intrinsically safe for use in hazardous areas
- On site actuator configuration and data download
- Data transfer from actuator to PC with free Rotork Insight software
- Capacity for 10 configuration and 4 datalogger files
- Multiple configuration capability

Note: Setting Tool Pro data transfer capability is compatible only with IQ actuators supplied since 2000.

Actuator display

IQ Pro incorporates a unique liquid crystal display developed specifically for actuator indication. The unique, diffused LED backlighting system has a top section which indicates valve position and is operational over the full operating temperature range of the actuator. Large segments with backlighting allow clear visibility of valve position in all light conditions.

The lower section shows real time valve, control and actuator status, torque and alarm messaging during operation. Using the Setting Tool changes the display from position mode to set-up mode, allowing the user to view, adjust and change actuator settings.

The LCD display is supplemented with green, yellow and red position indication lights.

The display together with the control cover can be rotated through 90° increments to suit valve orientation and access.

Indication back up

Rotork recognise the need for local and remote position indication at all times, even when the actuator is powered down. The IQ incorporates a battery to maintain and update position indication when the main power is switched off. The battery also supports data logging and commissioning whilst power is off.

Set-up

Infra-red set up, adjustment and review using the supplied, intrinsically safe IQ Setting Tool Pro gives users access to the configuration of the actuator.

Help screens

Eight help screens can be accessed with the IQ setting tool allowing real time, grouped analysis of control signal status, valve and actuator status and indication status.

Valve torque indication

Valve torque against position can be displayed in real time with a single setting tool keystroke. Trip levels set for torque switches can be checked and adjusted based on the actual valve operating torque requirements. This results in a more realistic and accurate set up, therefore reducing the need for future "snagging". Problems such as valve tight-spots, seating and breakout forces can be assessed immediately in the field.

SIL and high integrity control systems

IQ Pro SIL option is available for Safety Instrumented Systems (SIS) requiring a defined Safety Integrity Level 1, 2 or 3*. The TÜV™ certified IQ Pro SIL option provides dual redundancy for control operation making safety functions "Stay-put" and "ESD" (IQ range only) available. For more information refer to section 2 - Specifications.

For applications requiring higher integrity but not SIL defined, standard IQ Pro can be configured for conditional control.

* SIL3 applications may be met using a 1oo2 actuator configuration

In this mode, operation depends on two discrete signals being applied. As an example of a close valve command, by applying a signal to the remote close input and close conditional input simultaneously the actuator will operate and close the valve. If only one signal is applied, or a signal is lost, the actuators will stayput. For applications requiring ESD, the dedicated ESD input is available with a higher priority over local or remote control signals. This will therefore override any existing or applied control signal while it is applied.

Asset Management - Data logging

IQ Pro allows complete actuator configuration and build information to be downloaded and saved to PC. It also includes a data logger that captures and stores valve, actuator and control system status information in non-volatile memory, including:

- **Valve torque profile** - open/closed instantaneous and average torque profiles plotted against valve stroke. Reference profiles stored during commissioning can be compared to in-service torque profiles for valve performance analysis.
- **Starts log** – open/closed start positions plotted against valve stroke. Allows process control valve operation.
- **Statistics** – number of operations, highest recorded torque, last limit switch operation, battery run time, battery voltage.
- **Monitor log** – Control system, actuator and indication event log. Can be replayed and filtered for events of interest such as "torque trip". The last 1024 events are stored and stamped with date and time.

Using the IQ Pro IrDA™ interface, datalogger files can be downloaded to the IQ Pro tool or PDA running freeware IQ Pocket Insight for uploading to PC. IQ Insight PC based software is described in detail on page 12.



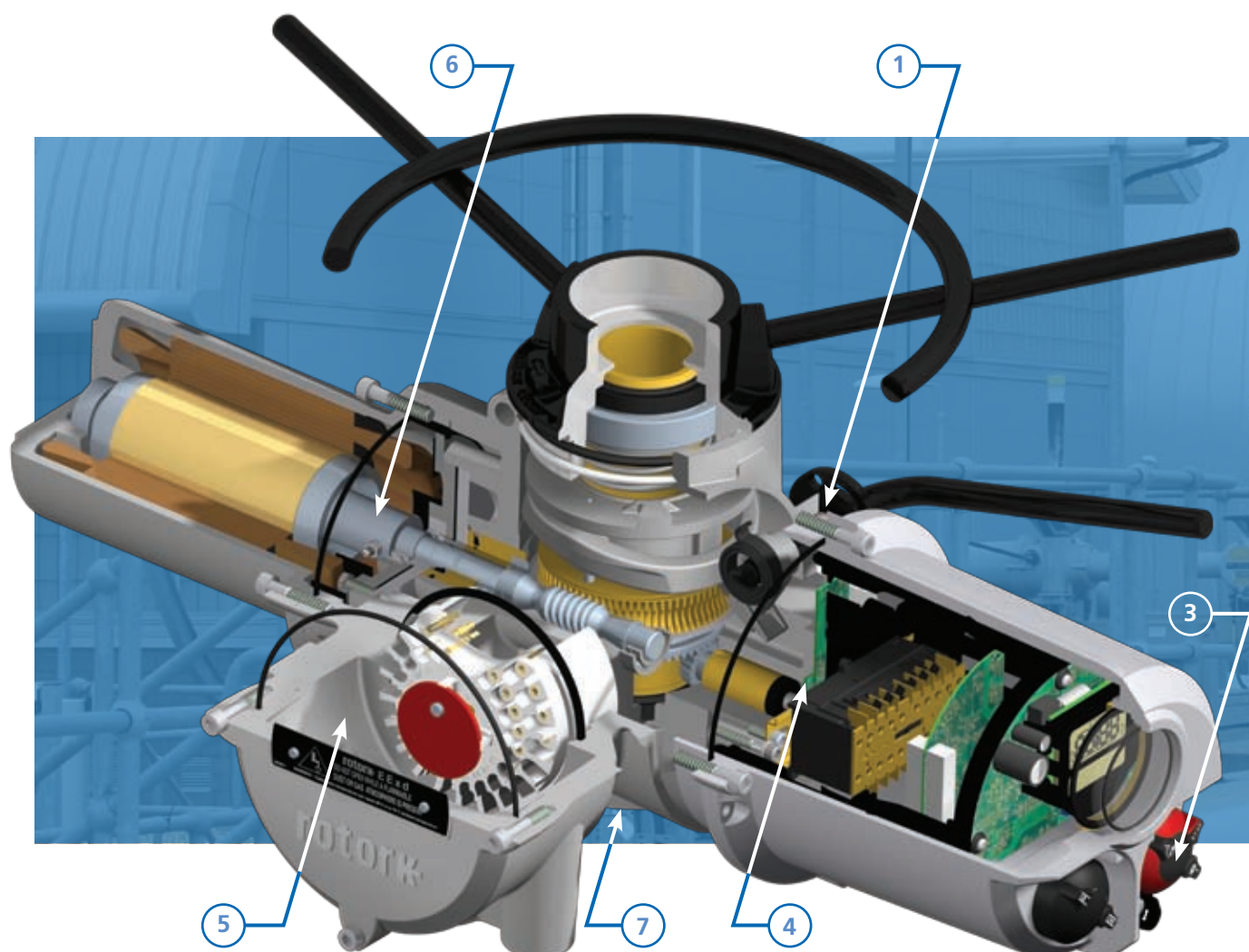

1 Hand operation

Direct drive handwheel (or geared handwheel on larger sizes and IQT) provides reliable emergency manual operation in the event of a power supply failure. Includes padlockable* hand/auto clutch for safe operation even when the motor is running.

Note: power operation always has preference unless hand/auto lever is purposely locked into 'hand drive'. Lost motion 'hammerblow' effect is provided with both direct and independently geared handwheels.

2 Non intrusive setting

All actuator settings and diagnostics are made through the sealed indication window using IrDA™ communication. It is not necessary to remove electrical covers which would expose the integral controls to the plant environment.

3 Local controls

Local controls and padlockable* Local/Stop/Remote selector switch operate internal reed switches, avoiding penetrating shafts which would have to be sealed to prevent moisture ingress.

4 Position control

Hall effect magnetic pulse system accurately measures and controls the stroke of the actuator without using gears and switches.

5 Terminal compartment

Separately sealed terminal compartment ensures the integrity of the electrical equipment even when the terminal cover is removed during on-site wiring.

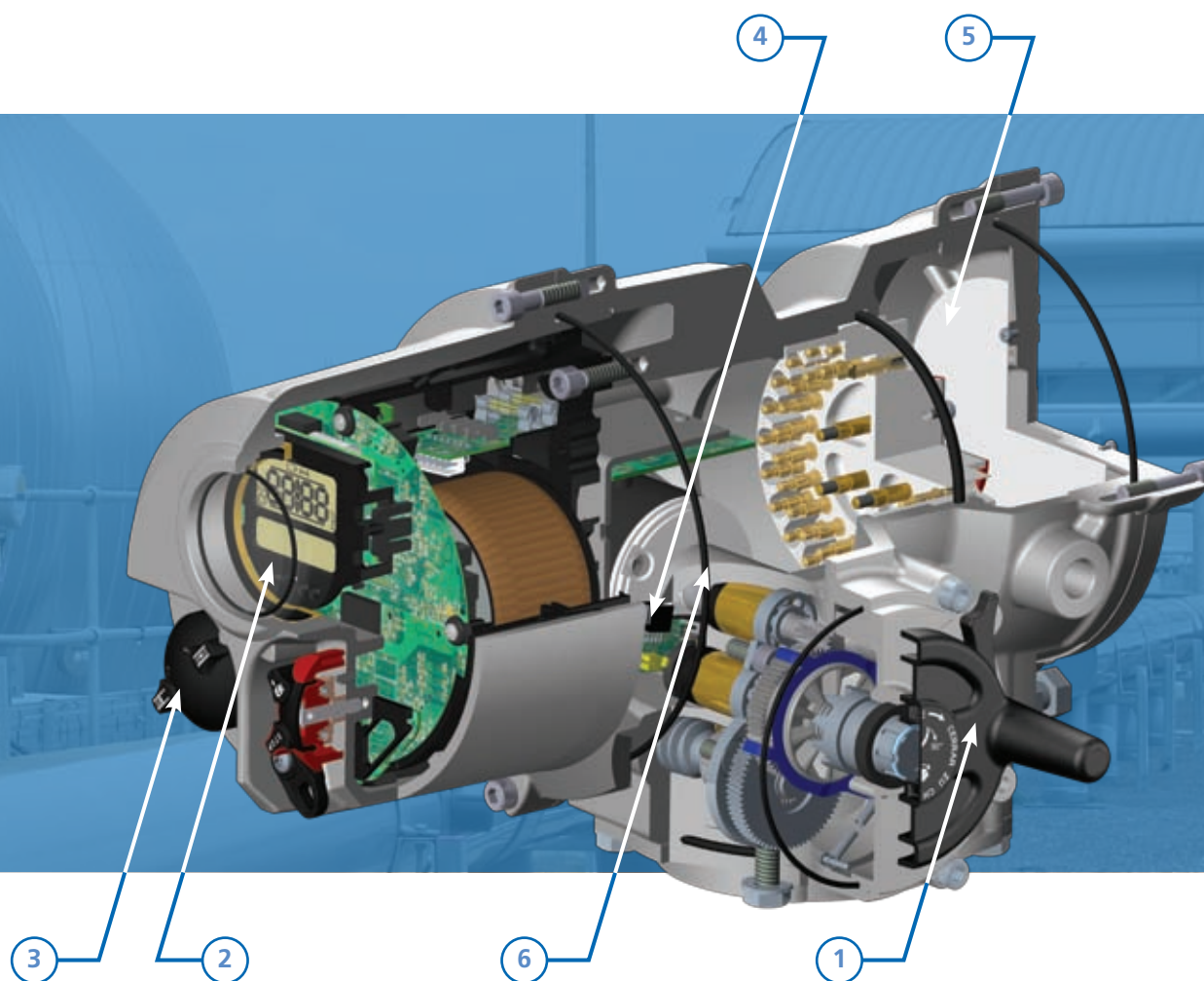

6 IQ motor and drive

The motor shaft and worm shaft separate to facilitate simple actuator speed change. The motor has low inertia and high torque. Peak torque is produced rapidly after starting but with very little overrun when de-energized.

The winding thermostat provides accurate temperature sensing, independent of ambient temperature conditions, to optimize the motor's thermal capacity. The motor drive includes a lost motion 'hammerblow' to assist in unseating tightly shut valves. A single worm and wheel drive run in an oil bath for maximum life with ambient temperature tolerance.

IQT motor

This is a high efficiency compact unit with a proven reliability record in valve actuation applications over 20 years. Integrated speed control allows output speed adjustment over a 4:1 speed range.

7 Thrust base

Cast iron, water sealed bearings. Easily removable drive bushing for machining to suit valve stem for convenient valve adaptation.

*Minimum 6mm / 1/4 inch padlock

Design Features – Reliability



Synctrophase prevents valve damage caused by incorrect wiring

Rotork's 'Synctrophase' automatic phase rotation correction control prevents valve damage caused by incorrect wiring by ensuring that the IQ three-phase motor is always presented with the correct phase rotation. Synctrophase senses the incoming phase rotation then energises the appropriate contactor to cause movement in the correct direction.

Single phasing protection*

IQ Pro control monitors all three phases of the power supply. Should one or more phases be lost the control system inhibits operation, preventing motor "single phasing" and burn out. The actuator display will indicate "phase lost", remote indication is also available from the configurable indication contacts.

Valve jammed protection

The actuator faces its severest operating test during unseating of the valve, when operating forces are at their highest or where an infrequently operated valve can get stuck. IQ Pro has the intelligence to systematically cope with these demands, ensuring reliable valve operation together with valve and actuator protection.

If valve "sticking" is considered possible, as with a wedge gate type, the torque switches can be by-passed during the first 5% of travel away from the valve seated position. This allows "extra" torque, averaging between 1.4 times and 2 times rated, to be applied in unseating the valve. In the majority of cases, applying additional force causes the sticky valve to move and allows operation to continue. After the 5% position has been reached, the torque switches return to the correct setting for the rest of travel. If this additional torque is still insufficient to cause movement IQ Pro recognises the valve is jammed and stops operation within seconds preventing further valve damage or motor burn out.

IQ thermostatic protection

In the event of overheating, two thermostats embedded in the motor windings directly sense the temperature and trip the actuator control circuit.

IQ thermostatic protection

Two thermostats are embedded within the motor power module providing comprehensive motor and motor power module protection.

Auto self test and diagnosis (ASTD)

Vital operational circuits automatically self test to ensure correct operation. In the unlikely event that a fault is diagnosed the information is automatically presented using the display text. At the same time, actuator operation can be inhibited to enable on-site investigation.

Instant reversal protection

When an actuator is ordered to reverse direction 'instantaneously' an automatic time-delay circuit avoids the shock loads which may cause unnecessary wear to valve stems and gearboxes. The delay also limits current surges through the contactor.

* IQ 3 phase only.





Protection - the key

Vast experience in the application of electric actuators has enabled Rotork to set the global standard in actuator ingress protection. Actuators have to perform unfailingly in environments ranging from desert to tundra, offshore to underground, where flooding, humidity, extremes of heat and cold, ultra violet and corrosive atmospheres are the norm. Rotork understands that the most important factor in the reliability of an actuator is protection from the environment - in simple terms, the enclosure.

Double sealed for double protection

The IQ enclosure is rated IP68 - 7 metres for 72 hours, NEMA 4/4X/6. It is completely watertight and dusttight and does not "breathe". The Rotork 'Double Seal' system ensures protection of internal components, separating them from the cable gland and terminal compartment by a watertight terminal block. Protection is maintained during site installation when terminal covers are removed and is independent of cable gland sealing.

Non-intrusive - sealed for life

IQ covers need not be removed for site commissioning. All settings and adjustments are made using the supplied infra-red Setting Tool *Pro*, including speed setting for the IQT. After assembly in the controlled environment of our manufacturing facilities, air exchanges are eliminated - all internal components are completely protected for life. Non-intrusive control selectors mean there are no moving shafts penetrating the control enclosure.

Reliability through simplicity

The IQ combines simplicity of design while extending specification and performance.

Torque measurement

An actuator's ability to reliably and accurately determine the force applied in operating a valve is fundamental to providing good valve and actuator protection. The IQ range uses tried and tested technology, proven in industry. Accurate, repeatable torque measurement is achieved independent of variations in frequency, voltage and temperature.

Position measurement

Reliable process control depends on accurate positioning of the valve throughout travel. The patented IQ non-contacting position measuring system is the most simple design devised for actuator control to date. With only one moving part, the resolver converts output centre column rotation into an electronic signal, which is then compared to position limits stored within a safe, non volatile memory.

IQT speed control

By use of motor control technology proven in the AQ range over 20 years, the output speed of the IQT can be adjusted without affecting the torque output.

Design Features – Intelligent Communication

Lifetime support

Rotork understands its customer's need for back up support. The costs and penalties of plant downtime, delayed commissioning schedules and inappropriate maintenance are too high to allow for inefficient support.

With IQ - IrDA™ (Infra-red Data Association) communication and the onboard datalogger, the IQ now offers unrivalled support to provide complete product back up with analysis and configuration. With Rotork's unrivalled worldwide service, network expert advice is always close to hand.

Remote diagnosis - IrDA™

The IQ utilises IrDA™ communication for fast, safe, non-intrusive and standardised data exchange. Actuator set-up configuration can be analysed and, if required, changed. As every IQ includes an onboard data logger, operational data such as valve torque profiles, actuator events and statistics can be downloaded for detailed investigation. Data logger information can also be relayed to a user site base via an IrDA™ compatible PDA. After analysis, any changes to the actuator set-up configuration can be relayed back to the actuator.

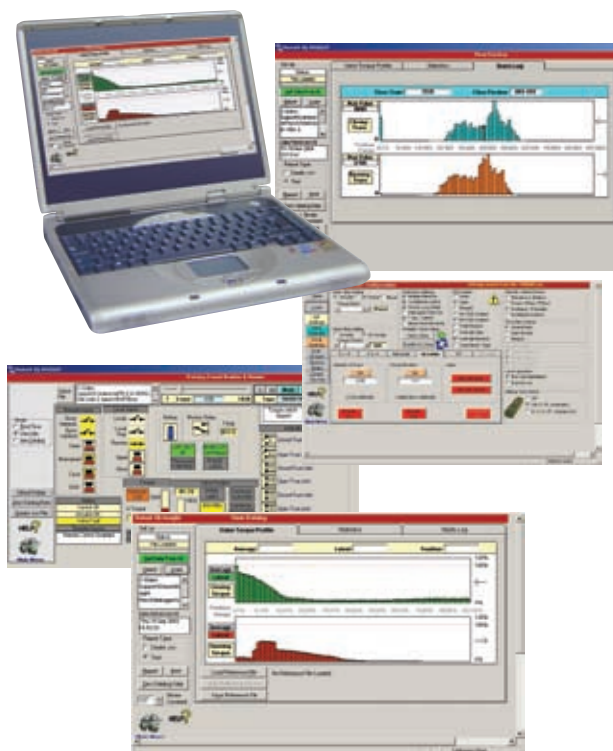

PC tools - IQ-Insight - Pocket-Insight

IQ-Insight PC software is a graphical user interface allowing all IQ set-up configuration and data logger information to be reviewed, analysed and reconfigured. This visually interactive application is browser based, running under Microsoft or other internet browser systems.

Intuitive controls make analysing the data from an IQ simple and fast. Laptop PCs with IrDA™ interface running IQ-Insight can be directly connected to an actuator located in the field to allow set-up, adjustment and analysis.

Alternatively, data can be uploaded from the actuator and later downloaded to a PC by using a PDA running IQ Pocket-Insight freeware.

Rotork help - online

Rotork has a comprehensive worldwide service network to provide you with local support wherever you are. Rotork trained technicians working from our network of offices and centres of excellence are available to offer immediate assistance.

To contact Rotork, visit www.rotork.com

Although Rotork's standard IQ Pro actuator offers wide ranging control and indication flexibility, a variety of features can be customised to individual customer requirements. IQT Pro provides direct operation of small to medium sized quarter-turn valves up to 2,000 Nm. IQ Pro actuators can also be fitted with part-turn worm and wheel gearboxes to provide increased torque at reduced speeds for the operation of part-turn valves. A sizing program for both part-turn and multi-turn applications is available on the rotork website www.rotork.com

IQTF (full turn) actuators

For non-thrust, multi-turn, slow speed applications, the IQTF provides a reliable solution with the same general specification as the IQT range.

For further details please contact Rotork.

Fireproofing and extreme cold

Fully operational at temperatures of up to +70°C, the standard IQ Pro range actuator can operate for up to thirty minutes in a fire (when temperatures may quickly climb to over 1,000°C)* through the use of boxes, blankets or intumescent coating, as specified by the customer.

With modifications the IQ Pro range actuator can also operate in temperatures as low as -50°C.

**For further details see publication S310E.*

Floor mounting for easy remote coupling

Floor stands with upward or downward stubshafts are available for coupling to remote valves via customer shafts and universal joints.

Linear output drive assemblies

For applications requiring an actuator with a linear output, a leadscrew arrangement can be fitted to the base of the standard IQ Pro actuator.

Damper actuators

Single blade and multi vane dampers can be motorised either by direct connection to the damper spindle or by lever arm.

Valve stem expansion

The stems of positive seating valves, such as solid or flexible wedge gates may be subject to significant expansion when used in high service temperature applications resulting in damaged or leaking valves. The effects of this expansion or contraction may be overcome by fitting the Rotork temperature compensator to the output of the IQ Pro actuator.

For further details see publication E152E.

Rotork Site Services division

Rotork Site Services, the projects, service and retrofit division - established in 2006 - is an illustration of Rotork innovation in practice. Throughout the company's history, aftermarket services such as retrofit and maintenance have developed to support customers and reinforce Rotork's market leading position. As a result, in some countries Rotork is now the number one service supplier for valve actuation. For detailed information on Rotork Site Services see page 18.

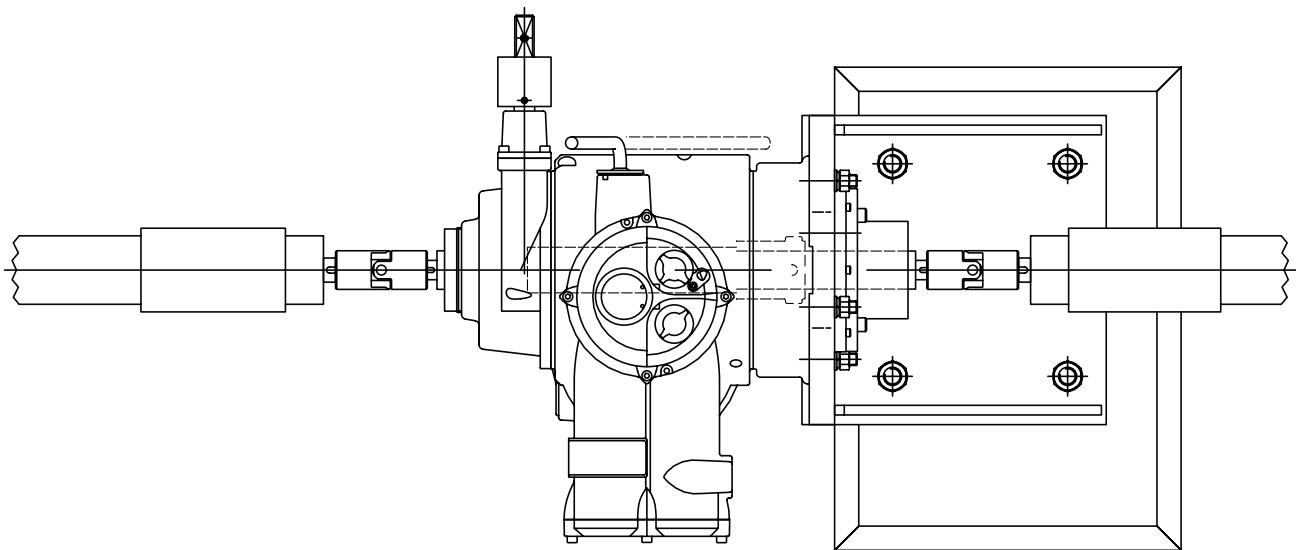

Pakscan Bus Control System



Integration of the plant controls by use of network connectivity has been a hallmark of Rotork actuator products for many years. The use of proprietary and open systems makes the commissioning of the plant and the subsequent control and monitoring a simple and reliable task.

All Rotork actuators are compatible with a wide range of communication and process controls systems by including the appropriate option card during manufacture of the actuator. The actuator reports status feedback, via the field highway, to the overall plant control system (DCS or PLC) and valve control commands are actioned.

Our own Pakscan system compliments the open systems from Foundation Fieldbus, Profibus, Modbus and DeviceNet see page 16 for more details. Innovative technology together with expert bus system knowledge ensures that Rotork can always provide the ideal solution for the control system.

Rotork Pakscan - the total control solution

Whether you need remote control of a few motorised valves, or full automation of a complex plant, Pakscan can help you to achieve significant savings in both time and costs.

Pakscan allows the remote control of actuators and valves over a simple single twisted pair data highway, removing the need for heavy multicore cables. It also includes automatic inbuilt redundancy of the field network to ensure control will be maintained even in the event of equipment or cable failure.

Available as a single or hot standby master station variant, Pakscan has the ability to control up to 240 actuators, and other field devices, using secure field communications. The field data highway cable may be up to 20 km in length so even quite distant valves can easily be incorporated into the network, without the need for repeaters.

Simple to install and simple to use, the highly successful Pakscan system has proved its value on many varied sites with over 70,000 Pakscan actuators installed worldwide.



Rotork Pakscan P3 master station

The Pakscan P3 master station incorporates a local HMI which has a full colour integral display showing the status of all the field devices, the current state of the communications ports, system alarms and diagnostic information plus actuator control and set up facilities. The simple 5 button keypad provides easy navigation through the display screens.

Remote access to the asset management features are available via the built in web pages as well as the status, diagnostic, set up and control facilities provided by the local HMI. Asset management information includes historical master station command log, host port analyser, automatic alarm notification via e-mail and event loggers for both the master station and field control units. Web security is provided by named IP access, https (secure web pages) and password protection

The two serial and two ethernet host ports allow for redundant communication. Pakscans pre-configured database and vast interface experience ensure smooth integration with any Modbus host system.

For further details see publication S001E.

Rotork P3 Field Mount master station

The Rotork P3 Field Mount (P3F) master station enhances the P3 product range by allowing the master station to be mounted close to the process. Enclosed in an environmentally protected IP65 box, it provides (via a DCS or PLC) control and monitoring of 32 field units utilising serial or TCP/IP Modbus communications. Configuration is achieved using the comprehensive built in web pages.

In-Vision - powerful, user-friendly

In-Vision is a SCADA (Supervisory Control And Data Acquisition) software application for full, user friendly control of complex installations, such as oil storage depots and water treatment plants, where there may be a high number of actuators and process signals to control and display.

Working with Pakscan and running on a standard PC, In-Vision offers a highly flexible series of graphic displays and controls that allow plant managers to view and control all aspects of their process at a fraction of the cost of other comparable systems.

The TSI computer is designed specifically to match the Pakscan system and In-Vision and the installed package can be a full In-Vision system, or an In-Vision MD.

For further details see publication S210E.

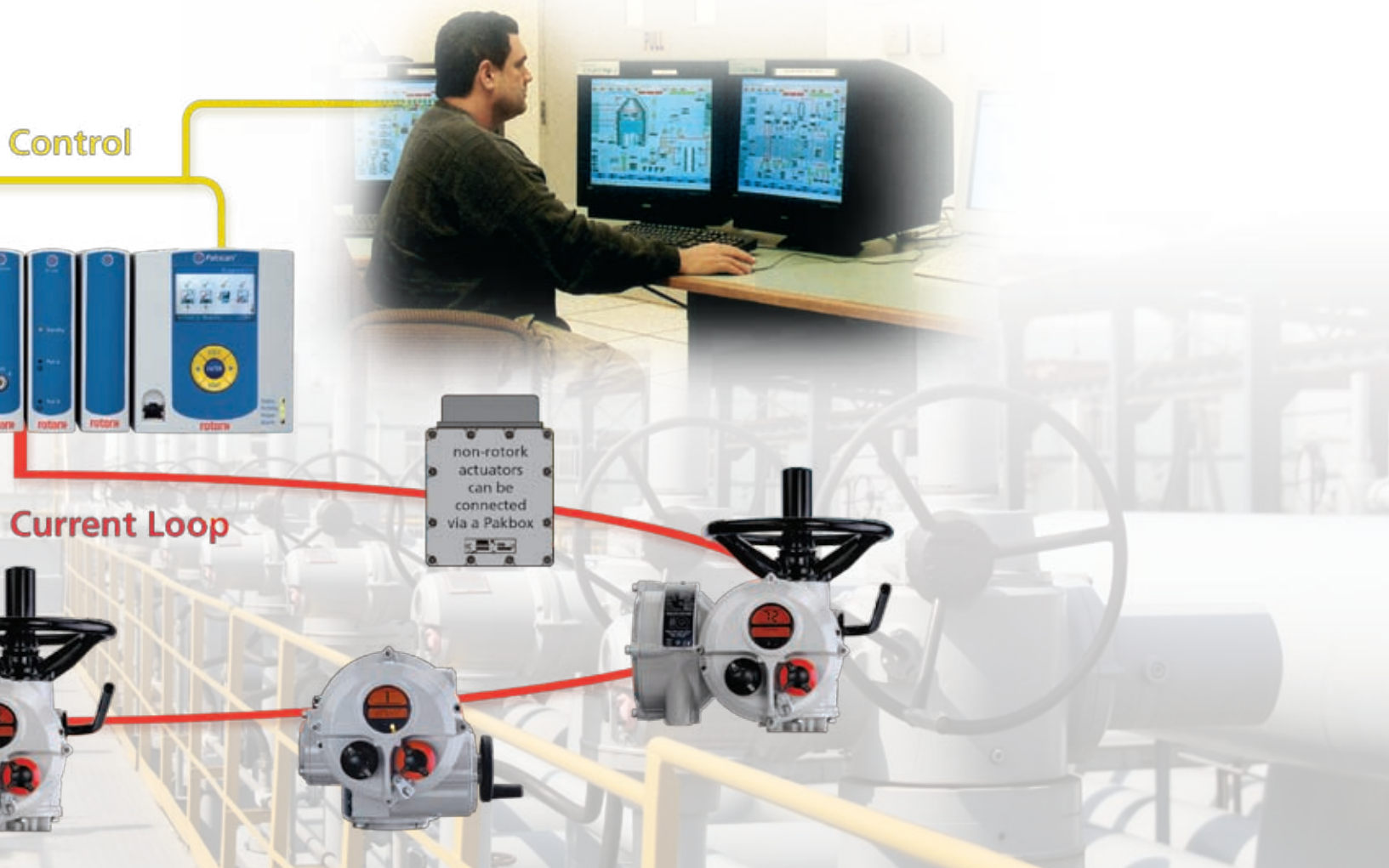

Multiple Bus Connectivity

Multiple fieldbus connectivity

In addition to being fully compatible with Rotork Pakscan, IQ Pro actuators can be specified to interface seamlessly to many other fieldbus digital control systems. Open fieldbus protocols, such as Profibus, Foundation Fieldbus, DeviceNet and Modbus, are all available within the IQ actuator control option range.

This is achieved simply and cost effectively through fitting an appropriate Rotork manufactured circuit board module inside the actuator's electrical housing, normally at the time of production. Module commissioning and setup is carried out using a combination of the IQ Setting Tool Pro and the network commissioning tools used for the chosen protocol.



Profibus

Profibus is a leading international network protocol for high speed data communications in industrial automation and control.

The Rotork Profibus DP interface card provides comprehensive control and feedback data about the valve and actuator using DP-V0 cyclic communications whilst extended actuator diagnostics and configuration is included in the DP-V1 acyclic data supported by this module.

EDD and DTM files allow the Rotork device to be incorporated into asset management systems giving access to performance critical parameters, whilst the independently certified GSD file guarantees device interoperability.

Rotork provide an optional switch disconnect module allowing for ease of installation and have multiple configuration options within the GSD file to enable a choice of data collection.

- RS485 Profibus DP V0 and V1 compliant
- Single and Dual Redundant options
- Fully meets IEC61158-3 standard
- Profibus PNO certified
- Supports speeds up to 1.5Mbit/s



Foundation

Foundation Fieldbus has become widely accepted for use in process control systems. It's primary feature is the ability to distribute control away from the central DCS.

The Rotork Foundation Fieldbus interface card connects directly onto the standard Foundation H1 bus system. The function blocks embedded in the module cover the control and monitoring of the valve and actuator.

Using the certified Device Description files the FF card is simple and easy to use. The ability to report extensive actuator feedback within a single input block as well as system diagnostic information makes Rotork the first choice for use with a Foundation Fieldbus system.

- Foundation ITK inter-operability certified
- Fully compliant with IEC61158-2 standard
- Includes Link Master and LAS capability
- Independent HIST approval by major DCS vendors
- Full H1 Field capability

Modbus®

Modbus

Modbus remains the most popular process communication protocol in use today with the widest acceptance and highest number of applied systems of any automation protocol.

Rotork's Modbus interface card allows actuators to be connected to a 2 wire RS485 network for direct communication to a PLC or DCS using Modbus RTU protocol. The resulting network is able to monitor and control the connected actuator.

As the Modbus protocol is so simple the system engineer has full control over the data flow on the highway and the information to be collected and controls implemented.

There are no complications with device description files or special programming tools required when setting up a Modbus system.

- RS485 2 wire RTU communication
- International open standard
- Single and Dual redundant options
- Integral Repeater modules included where necessary
- Up to 115 kB



DeviceNet

DeviceNet is an Open Network Standard for communication networks using the main features of CAN bus in an industrial environment.

The Rotork DeviceNet interface module provides easy access to actuator process control and feedback information. The Electronic Data Sheet description file is used to set up the actuator parameters to allow the systems performance to be optimised,

In addition to the standard actuator torque and position feedback a further analogue input is included as standard enabling integration of external analogue equipment onto the network.

The Rotork module has been certified by the Open DeviceNet Vendor Association to ensure its interoperability with other devices.

- Up to 63 devices on each network
- 4 wire cable, 2 for signal, 2 for power
- Trunk and Drop line permitted
- ODVA certified to ensure compatibility
- EDS electronic device description file

Rotork Site Services

Rotork Site Services division, bringing together project, service and retrofit activities, is active in 47 service centres in over 20 countries, with agents providing support services in a further 55 countries. The total number of expert technicians supporting Rotork customers is well over 1,000.

The division provides services in maintenance, management and the upgrading of installed actuation assets in order to fully support and satisfy the increasing demands for these activities from customers throughout the world. The services are tailored to meet customers' specific needs, encompassing the following:

Emergency and Planned Service

Available for all types of actuator, in all areas (including hazardous environments). Some customers require guaranteed emergency response times, others require planned response for all types of actuator work, including installation, commissioning, upgrading, connection and installation of bus communication systems, troubleshooting and repair of damaged or deteriorating assets.

Actuator Overhauls

After a long service life customers may prefer their actuators to be completely overhauled rather than replacing them with new ones. In our workshops we completely strip and rebuild actuators, returning them to their original state.

Health Checks

Some customers lack detailed information on their assets, making it difficult to prioritise maintenance and replacement investment. We can carry out a detailed and intrusive inspection of the actuators and combine this with build data from our own databases to give customers a holistic view of their assets.

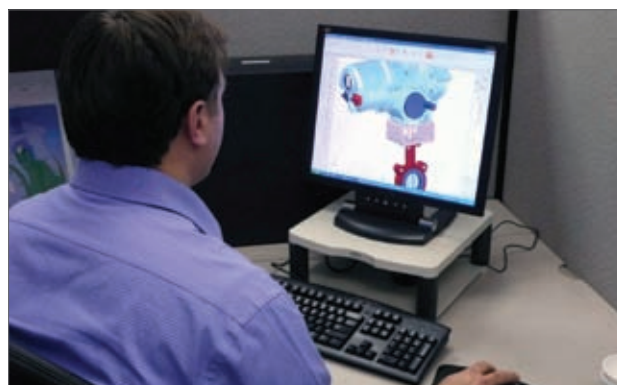

Retrofitting actuators to existing valves

We have extensive experience in fitting actuators to valves, penstocks and dampers that are already installed as part of existing plant. Whether customers are replacing obsolete actuators, changing power sources or motorising manual valves, we offer a tailor made solution to meet customers' specific requirements.



Shutdown Outages

We can support customers in making sure that all their actuators are fully operational and that they meet tight shutdown deadlines. For example some power stations look for us to remove and overhaul in our workshops over 200 actuators when taking a unit out for maintenance. We do this, reinstall and commission the actuators and, where requested, carry out additional actuation projects simultaneously to ensure that customers make the most of their plant shutdown time.



Preventative Maintenance

We provide regular scheduled maintenance to enhance the integrity of actuators and their associated valves. This service is typically sought by customers looking to maximise the up-time of their plant.

Factory fitting of actuators to new valves

The careful assembly of valve and actuator is critical to ensure that an automated valve performs correctly and reliably. Whilst this service is often carried out by valve manufacturers, if there is a need we can provide this service.



Extended scope projects

This is a growing requirement and some of our service teams have the wide range of skills necessary to offer a "one-stop-shop" to automate part or all of a customer's process. Our capabilities cover all of the installation phases (scoping, design, procurement, manufacturing, installation, commissioning) on the broad scopes that typically surround actuation projects.





Actuator Specification



The following pages contain details on performance and specification for the Rotork IQ range of actuators.

Please use the following contents table to help access the information you require.

1	Performance summaries	p22
2	Actuator Drive Couplings	p28
Standard Specification - IQ & IQT		
3	Introduction	p30
	Standard Specification	p31
4	Valve Type – Actuator Selection Guideline	p32
5	Design Specification	p33
5.1	Duty Rating	p33
5.2	Design Life	p33
5.3	Vibration, Shock and Noise	p33
5.4	Valve / Actuator Interface	p34
5.5	Operating Temperature	p34
6	Non-Hazardous & Hazardous Certified Enclosures	p34
6.1	Non-Hazardous Area Enclosures	p35
6.2	Hazardous Area Enclosures	p35
7	Regulatory Standards	p37
8	Power, Control & Indication	p38
8.1	Power Supplies	p38
8.2	Local Control, Indication & Set-up	p39
8.3	Remote Control & Indication	p41
8.4	Fieldbus System Control Options	p43
8.5	Functional Safety - Safety Integrity Level Applications	p43
9	Protection & Operating Features	p44
10	Components	p46
10.1	Handwheel	p46
10.2	Lubrication	p47
10.3	Finish	p47
10.4	Motor	p48
10.5	Power Module	p49
10.6	Torque Sensor	p49
10.7	Position Sensor	p49
10.8	Control Module	p50
10.9	Conduit / Cable Entries	p51
10.10	Terminals	p51
10.11	Wiring	p51
10.12	Battery	p51

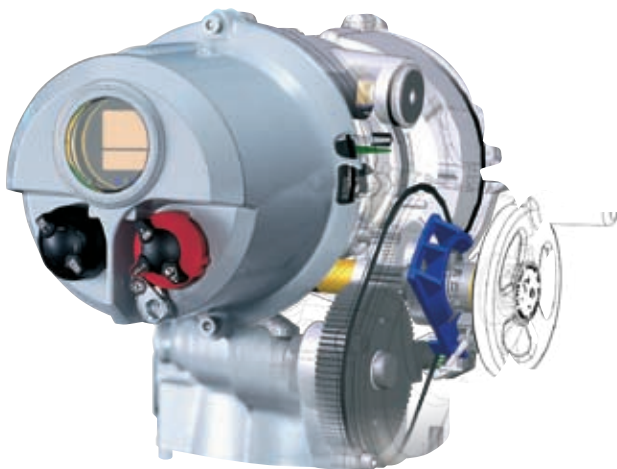



IQ 3 Phase Performance Summary

Performance Data

	Actuator output speeds							
rpm at 50 Hz	18	24	36	48	72	96	144	192
rpm at 60 Hz	21	29	43	57	86	115	173	230

Actuator size	Torque**								
		Nm	Ft lbf						
IQ10		34	34	34	34	34	34		
		25	25	25	25	25	25		
IQ12		81	81	81	68	48	41		
		60	60	60	50	35	30		
IQ18		108	108						
		80	80						
IQ20		203	203	203	203	176	142	102*	
		150	150	150	150	130	105	75*	
IQ25		400	400	298	244	244	230	149*	
		295	295	220	180	180	170	110*	
IQ35		610	610	542	474	474	366	257*	
		450	450	400	350	350	270	190*	
IQ40		1020	1020	845	680	680	542	406*	
		750	750	625	500	500	400	300*	
IQ70		1490	1490	1290	1020	1020	745	645*	542*
		1100	1100	950	750	750	550	475*	400*
IQ90		2030	2030	1700	1355	1355	1020	865*	730*
		1500	1500	1250	1000	1000	750	640*	540*
IQ91								1355*	1355*
								1000*	1000*
IQ95			3000						
			2200						

* Due to the effects of inertia and drive nut wear, speeds not recommended for direct mounted gate valve applications.

** Torque rating is maximum torque setting in both directions. Stall torque will be 1.4 to 2.0 times this value depending on speed and voltage.

If maximum torque is required for more than 20% of valve travel, refer to Rotork.

IQ Single Phase and IQ DC

IQ Single Phase - Performance Data

	Actuator output speeds						
rpm at 50 Hz	18	24	36	48	72	96	144
rpm at 60 Hz	21	29	43	57	86	115	173

Actuator size Torque**

Nm Ft lbf

Actuator size	Torque**						
	Nm	Nm	Nm	Nm	Nm	Nm	Nm
IQS12	65	60	45	40	30	25	
	48	44	33	30	22	18	
IQS20	165	130	130	125	100	80	60
	122	96	96	92	74	59	44
IQS35*	450	400	350	320	230	190	135
	332	295	258	236	170	140	100

IQ DC - Performance Data

	Actuator output speeds			
rpm	18	24	36	48

Actuator size Torque**

Nm Ft lbf

Actuator size	Torque**			
	Nm	Nm	Nm	Nm
IQD10	34	34	31	27
	25	25	23	20
IQD12	68	68	61	54
	50	50	45	40
IQD18		108		
		80		
IQD20	163	163	136	108
	120	120	100	80
IQD25	305	305	257	203
	225	225	190	150

DC supply voltage

24V

48V

110V

IQD10	✓	✓	✓
IQD12	X	✓	✓
IQD18	X	✓	✓
IQD20	X	X	✓
IQD25	X	X	✓

* **IQS35 not available at 115v.** Actuator output speed 144/173 rpm is not recommended for direct mounted gate valve applications.

** Torque rating is maximum torque setting in both directions. Stall torque will be 1.4 to 2.0 times this value depending on speed and voltage.

If maximum torque is required for more than 20% of valve travel, refer to Rotork.

IQ Performance Summary

Mechanical Data

Actuator size IQ IQS IQD	10	20	35	40	70	90	91	95
	12	25						
	18							

Flange size	ISO 5210	F10	F14	F16	F25	F25	F30*	F25	F30
	MSS SP - 102	FA10	FA14	FA16	FA25	FA25	FA30*	FA25	FA30

Approximate weight**	kg	27	46	69	190	190	200	200	200
	lbs	60	101	152	418	418	440	440	440

Group 'A' couplings (thrust)

Thrust rating	kN	44	100	150	220	220	334	N/A	445
	lbf	10,000	22,480	33,750	50,000	50,000	75,000	N/A	100,000

Stem acceptance diameter Type 'A' (maximum)

Rising	mm	32	38	54	64	70	70	N/A	N/A
	ins	1¼	1½	2⅛	2½	2¾	2¾	N/A	N/A

Non-rising	mm	26	32	45	51	57	57	N/A	N/A
	ins	1	1¼	1¾	2	2¼	2¼	N/A	N/A

Type 'Z' - 'Z3'

Z Rising	mm	N/A	51	67	N/A	N/A	N/A	N/A	N/A
	ins	N/A	2	2⅝	N/A	N/A	N/A	N/A	N/A

Z3 Rising	mm	32	51	67	73	83	83	N/A	83
	ins	1¼	2	2⅝	2⅞	3¼	3¼	N/A	3¼

Non-rising	mm	N/A	38	51	57 ††	73 ††	73 ††	N/A	73 ††
	ins	N/A	1½	2	2¼ ††	2⅞ ††	2⅞ ††	N/A	2⅞ ††

Group 'B' couplings (non-thrust) Bore diameter

Type 'B1' (fixed bore)	mm	42	60	80	100	100	120	100	N/A
------------------------	----	----	----	----	-----	-----	-----	-----	-----

Type 'B3' (fixed bore)	mm	20 †	30 †	40 †	50	50	50	50	N/A
------------------------	----	------	------	------	----	----	----	----	-----

Type 'B4' (maximum)	mm	20 †	32 †	44 †	50	60	60	60	N/A
	ins	¾	1¼	1¾	2	2¼	2¼	2¼	N/A

Handwheel ratio	Standard	Direct	Direct	Direct	Direct	15:1	15:1	15:1	15:1
	Optional	12:1	13.5:1	22.5:1	15:1 or 30:1	30:1	45:1	30:1	45:1

* IQ90 with B3 and B4 couplings have flange size F25. ** Weight will be dependent on optional equipment fitted.

† For actuator sizes IQ10 to IQ35 a type 'A' coupling must be used when required to drive shafts or stems having any axial movement.

†† Utilises Z3 form drive coupling.

IQT Quarter-Turn Performance Summary



Performance and Mechanical Data

Actuator	IQT125	IQT250	IQT500	IQT1000	IQT2000
Torque					
Max Nm	125	250	500	1000	2000
Min Nm	50	100	200	400	800
Max Ft lbs	92	185	369	738	1476
Min Ft lbs	37	74	148	295	590
Operating time					
90° Min	5	8	15	30	60
90° Max	20	30	60	120	120
Flange					
ISO 5211	F05* F07* F10	F07* F10	F10	F12 F14*	F14
MSS SP-101	FA05* FA07* FA10	FA07* FA10	FA10	FA12 FA14*	FA14
Weight					
Kg	22	22	22	37	37
lbs	49	49	49	82	82
Couplings**					
Spindle acceptance					
Bore & key max mm	22 28 42	28 42	42	60	60
Bore & key max ins	0.87 1.1 1.65	1.1 1.65	1.65	2.36	2.36
Square AF max mm	14 19 32	19 32	32	41	41
Square AF max ins	0.56 0.75 1.25	0.75 1.25	1.25	1.62	1.62
Handwheel					
Turns for 90°	80	80	80	80	80
Angular adjustment					
(nominal) degrees	80 - 100	80 - 100	80 - 100	80 - 100	80 - 100

IQT 24V DC (17-37 Volts) Performance

Torque outputs for 24V DC are the same as above, however speed varies with load.

* Optional flanges F05, FA05, F07 and FA07 use a base adapter plate. Required base type must be specified.

** Couplings are supplied blank for machining by valve maker.



IQM and IQML Performance Summary

Performance Data

Actuator size	Base sizes to ISO 5210	Thrust rating	Max. rising stem dia.	Actuator output speeds										
				rpm at 50 Hz		24		36		48		72		
				rpm at 60 Hz		21		29		43		57		86
				Torque**		Nm		lbs ft						
IQM10	F10	44 kN	32 mm	Modulating torque	17	12.5	17	12.5	15.6	11.5	13.6	10	-	-
		10,000 lbf	1.25 ins		Max. seat. torque	34	25	34	25	30	23	27	20	-
IQM12	F10	44 kN	32 mm	Modulating torque	34	25	34	25	30	22	27	20	-	-
		10,000 lbf	1.25 ins		Max. seat. torque	61	45	54	40	54	40	48	35	-
IQM20	F14	100 kN	51 mm	Modulating torque	81	60	81	60	68	50	54	40	47	35
		22,480 lbf	2 ins		Max. seat. torque	122	90	109	80	81	60	68	50	54
IQM25	F14	100 kN	51 mm	Modulating torque	152	112.5	152	112.5	129	95	102	75	102	75
		22,480 lbf	2 ins		Max. seat. torque	204	150	204	150	163	120	136	100	136
IQM35	F16	150 kN	54 mm	Modulating torque	271	200	271	200	253	187	203	150	203	150
		33,750 lbf	2 1/8 ins		Max. seat. torque	544	400	544	400	408	300	313	230	218

Actuator size	Base sizes to ISO 5210	Leadscrew dia/lead mm	Stroke Length	Speed at										
				50 Hz		60 Hz		Thrust		kN		lbf		
IQML10	F10	25 / 3	115 mm 4 1/2 ins	Linear speed mm / sec	0.9	1.1	1.2	1.4	1.8	2.2	2.4	2.9	-	-
				Modulating thrust	7.94	1785	7.94	1785	7.3	1643	6.35	1429	-	-
				Rated seating thrust	15.88	3570	15.88	3570	14.61	3285	12.71	2858	-	-
IQML12	F10	25 / 3	115 mm 4 1/2 ins	Linear speed mm / sec	0.9	1.1	1.2	1.4	1.8	2.2	2.4	2.9	-	-
				Modulating thrust	15.9	3571	15.9	3571	14.3	3214	12.7	2860	-	-
				Rated seating thrust	28.59	6428	25.42	5714	25.42	5714	22.26	5005	-	-
IQML20	F14	38 / 7	115 mm 4 1/2 ins	Linear speed mm / sec	2.1	2.5	2.8	3.4	4.2	5.0	5.6	6.8	8.4	10.1
				Modulating thrust	24.36	5455	24.26	5455	20.22	4545	16.17	3636	14.15	3182
				Rated seating thrust	36.4	8183	36.4	8183	24.26	5454	20.2	4545	16.1	3636
IQML20	F14	38 / 15	115 mm 4 1/2 ins	Linear speed mm / sec	4.5	5.4	6.0	7.2	9.0	10.8	12.0	14.4	18.0	21.6
				Modulating thrust	16.7	3750	16.7	3750	13.9	3125	11.1	2500	8.9	2000
				Rated seating thrust	25.1	5625	25.1	5625	16.7	3750	13.9	3125	11.1	2500
IQML25	F14	38 / 7	115 mm 4 1/2 ins	Linear speed mm / sec	2.1	2.5	2.8	3.4	4.2	5.0	5.6	6.8	8.4	10.1
				Modulating thrust	45.49	10227	45.49	10227	38.41	8636	30.33	6818	30.33	6818
				Rated seating thrust	60.7	13636	60.7	13636	48.5	10908	40.4	9090	40.4	9090
IQML25	F14	38 / 15	115 mm 4 1/2 ins	Linear speed mm / sec	4.5	5.4	6.0	7.3	9.0	10.8	12.0	14.4	18.0	21.6
				Modulating thrust	31.3	7031	31.3	7031	26.4	5937	20.85	4687	20.85	4687
				Rated seating thrust	41.7	9375	41.7	9375	33.3	7500	27.8	6249	27.8	6249

IQTM Performance Summary



	Torque						Operating Time 90° Max
	Max Nm	Modulating Nm	Min Nm	Max Ft lbs	Modulating Ft lbs	Min Ft lbs	
IQTM125	125	62.5	50	92	46	37	20
IQTM250	250	125	100	185	92.5	74	30
IQTM500	500	250	200	369	184.5	148	60
IQTM1000	1000	500	400	738	369	295	120
IQTM2000	2000	1000	800	1476	738	590	120



Actuator Drive Couplings

The IQ *Pro* range features two actuator base designs - a removable base for the IQ10, 12, 18, 20, 25 and 35 sizes and an integral base for IQ40, 70, 90, 91 and 95. Both arrangements are available with flanges and couplings that comply with either ISO 5210 or MSS SP-102.

Thrust Bearings

Both type 'A' and 'Z' couplings feature an associated thrust bearing. In the case of the removable thrust base this is fully sealed and lubricated for life; in the integral base design this is lubricated by the actuator gearcase oil bath. Both integral and removable thrust bases are designed to retain all developed thrust reaction forces without any load appearing on the actuator gearcase.

Drive Couplings

For convenient valve adaption the easily removable drive bush is supplied blank for machining to suit valve stem. The IQT *Pro* base design and drive couplings comply with either ISO 5211 or MSS SP-101.



IQ Actuator Drive Couplings

IQ10 to IQ35

Actuators:

IQ10 IQ12 IQ18
IQ20 IQ25 IQ35

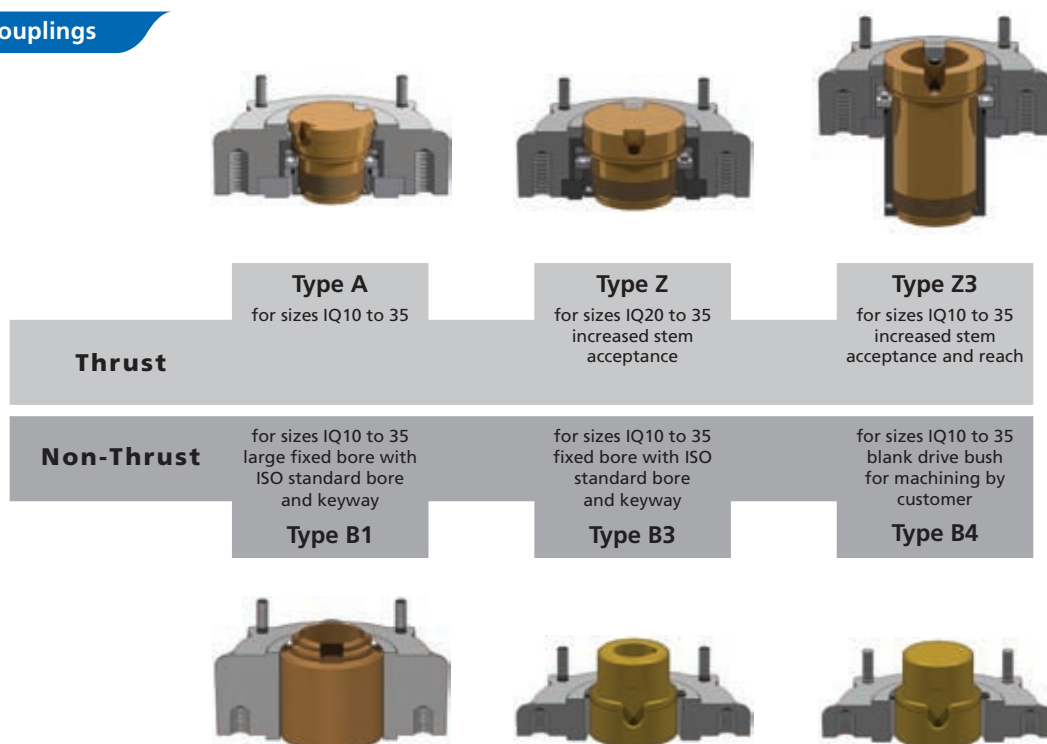

IQ Actuator Drive Couplings

IQ40 to IQ95



Actuators:
IQ40 IQ70 IQ90
IQ91 IQ95

	position 1	Type A for sizes IQ40 to 90	position 2	Type Z3 for sizes IQ40, 70, 90 and 95 increased stem acceptance and reach
Thrust				
Non-Thrust	for sizes IQ40, 70 and 90 large fixed bore with ISO standard bore and keyway		for sizes IQ40, 70, 90 and 91 fixed bore with ISO standard bore and keyway	for sizes IQ40, 70, 90 and 91 blank drive bush for machining by customer
	Type B1		Type B3	Type B4

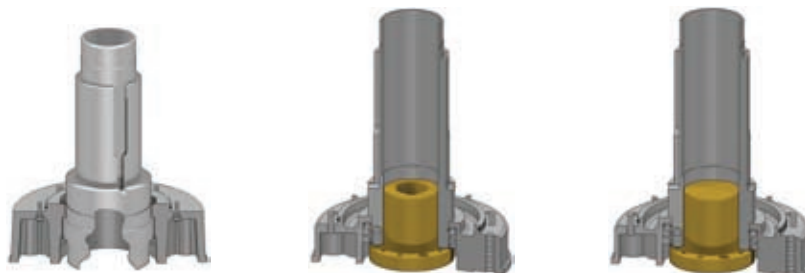

IQT Actuator Drive Couplings

Actuators:
IQT125 IQT250
IQT500

	F05/FA05 for size IQT125	F07/FA07 for sizes IQT125/250	F10/FA10 for sizes IQT125/250/500
--	------------------------------------	---	---

Actuators:
IQT1000 IQT2000

	F12/FA12 for size IQT1000	F14/FA14 for size IQT2000
--	-------------------------------------	-------------------------------------

Standard specifications

3 Introduction

IQ Pro & *IQT Pro* range actuators are self contained, purpose designed and built for the local and remote electrical operation of valves. Comprising an electric motor, reduction gearing, reversing starter with local controls and indication, turns and torque limitation with electronic logic controls and monitoring facilities housed in a double-sealed watertight enclosure. Hazardous area certified enclosures meeting international and national requirements are also available.

All torque, turns settings and configuration of the indication contacts are made using the non-intrusive, hand held, infra-red *IQ Pro* Setting Tool which is included with each order.

The specification detail in this section covers standard features and available optional features for the *IQ Pro* and *IQT Pro* range. Enclosure requirements and build options selected must be specified with enquiry.

The selection guideline in section 4 allows specifiers to identify suitable actuator types for particular valve and process applications, checking actuator type against other specification requirements.

The example enquiry datasheet opposite provides an outline of the basic information required for quotation. Where there is a project, framework or job specification applicable, Rotork will be pleased to analyse it in detail, in which case only valve details are required. The applicable actuator specification detail paragraph number is listed under the reference column for information.

It is not necessary to specify the actuator type, size or speed – Rotork will provide the most cost effective solution based on the information provided.



Standard specifications



Page	Requirement	Options	Detail
32	Valve type	Part turn	Ball/butterfly / plug – or other (specify)
		Multi-turn	gate/globe / penstock/sluiice or other (specify)
33	Duty cycle	Isolating	Starts / hour
		Regulating	Starts / hour
		Modulating	Starts / hour
22	Operating time or turns	Sec	Turns
22	Seating Torque	Nm	Lbs / ft
22	Running torque (if known)	Nm	Lbs / ft
22	Thrust (multi turn only)	kN	Lbsf
38	Power supply	1-phase	___Volts ___Hz
		3-phase	___Volts ___Hz
		DC	___Volts DC
38	Failsafe	No	
		Self contained	
		UPS or Battery	
34	Enclosure	Non-hazardous	IP / Nema rating
		Hazardous	Standard
39	Local indication	Position display plus text display	Language required
41	Remote Control	Contacts	Actuator powered / Control system powered
		Analogue	4-20mA other (specify)
		Digital bus-network	Type
41	Remote Indication	Volt free indication contacts	
		4-20mA position indication	
		Digital bus-network	

Standard specifications

4 Valve Type – Actuator Selection Guideline

Valve types are defined by the action required by the actuator for operation – multi turn, part turn or linear. The table below provides a guide to the actuators available and is determined by valve type, operating torque and duty requirement.

Actual selection may vary to those indicated below due to factors such as available power supply, mechanical interface, thrust requirements etc. Rotork will always offer the correct technical solution at the lowest cost for any application.

Valve Type	Duty*	Torque Min (Nm/lbsft)	Torque Max (Nm/lbsft)	Actuator Type	Comments
Multi-turn Gate valves	On-Off & Inching	13/10	3,000/2,200	IQ	General gate valves, penstock/sluiice, Parallel slide, globe, choke
Multi-turn Gate valves	On-Off & Inching	100/135	43,000/32,000	IQ + IS or IB gearbox	General gate valves, penstock/sluiice, Parallel slide globe, choke
Multi-turn Low turns – non thrust	On-Off & Inching	1,000Nm		IQ + MTW gearbox	Non-thrust applications such as cable operated river gates
Multi-turn Control valve	Modulating	13/10	544/400	IQM	Control valves such as globe/cage/choke
Multi-turn Control valve	Modulating	400	21,000/15,500	IQM + IB/IS gearbox	Control valves such as globe/cage/choke
Part turn	On-Off & Inching	50/37	2,000/1,500	IQT	General 1/4 turn ball/butterfly/damper
Part turn	On-Off & Inching	1,000/740	500,000/370,000	IQ + IW gearbox	General 1/4 turn ball/butterfly/damper
Part turn	Modulating	40	2,000	IQTM	1/4 turn control valves ball, butterfly, damper
Part turn	Modulating	400	2100	IQM + MOW gearbox	1/4 turn control valves ball, butterfly, damper
Linear	On-Off & Inching	Thrust 5.6kN/1260lbsf	Thrust 100kN/22,400lbsf	IQL	General gate valves, globe, choke
Linear	Modulating	Thrust 6.3kN/1428lbsf	Thrust 60kN/13,636lbsf	IQML	Control valves such as globe/choke/cage

5 Design Specification

5.1 Duty Rating

Duty Classification*	Actuator Type	Rating
On-Off & Inching	IQ / IQS / IQD	Nominal 60 starts per hour at a rate not exceeding 600 starts per hour. 15 minutes rated based on a nominal torque of 33% of rated
On-Off & Inching	IQT / IQTF	Nominal 60 starts at a rate not exceeding 600 starts per hour. 15 minutes rated based on a nominal torque of 75% of rated
Modulating	IQM	Nominal 1,200 starts per hour, 50% duty cycle based on a modulating torque of 50% of rated torque
Modulating	IQTM	Nominal 1,200 starts per hour, 50% duty cycled based on a modulating torque of 50% of rated torque

5.2 Design Life

Duty Classification*	Actuator Type	Size	Minimum Design Life Rating
On-Off & Inching	IQ / IQS / IQD	10 - 35	Torque and thrust test: 10,000 cycles (500,000 output turns) seating at rated torque, 33% rated torque through stroke
		40 - 95	Torque and thrust test: 5,000 cycles (250,000 output turns) seating at rated torque, 33% rated torque through stroke
Modulating	IQM	12-35	1,800,000 starts at load of 50% rated torque (1 start constitutes at least 1° movement)
On-Off & Inching	IQT / IQTF	All sizes	Torque test: 25,000 cycles seating at rated torque, 70% rated torque through stroke
Modulating	IQTM	All sizes	1,800,000 starts at load of 70% rated torque (1 start constitutes at least 1° movement)

Design life is a function of actuator torque and speed. Values quoted are the minimum requirements; for most sizes/speeds life will be extended above the values quoted. Actuators are stalled against a solid object 25 times to prove durability. Contact Rotork for more information

5.3 Vibration, Shock and Noise

Standard IQ and IQT Range actuators are suitable for applications where vibration and shock severity does not exceed the following:

Type	Level
Plant induced vibration	1g rms total for all vibration within the frequency range of 10 to 1000Hz
Shock	5g peak acceleration
Seismic	2g acceleration over a frequency range of 1 to 50Hz if it is to operate during and after the event
Emitted noise	Independent tests have shown that at 1m generated noise does not exceed 61db(A)

Levels quoted are those present at the actuator mounting interface. It should be noted that the effects of vibration are cumulative and therefore an actuator subjected to significant levels may have a reduced lifespan. Where excessive plant induced vibration is anticipated, mounting the actuator remote from the valve and driving via extension shafting (incorporating vibration absorbing couplings) may provide a satisfactory solution.



Standard specifications

5.4 Valve / Actuator Interface

The IQ *Pro* and IQT *Pro* range of actuators are available with mounting base and output drive couplings conforming to the following international standards:

Valve to actuator interface:

Valve type	Actuator Range	Area	Standard	Code
Multi-turn	IQ	International	ISO 5210	"F" metric
Multi-turn	IQ	USA	MSS SP-102	"FA" imperial
Part turn	IQT	International	ISO 5211	"F" metric
Part turn	IQT	USA	MSS SP-101	"FA" imperial

Applications for which the various types of couplings have been designed are outlined on pages 28/29.

5.5 Operating Temperature

Actuators are suitable for operation within the ambient temperature ranges shown below. Refer to Section 6 for Hazardous Area Certification operating temperature restrictions. For temperatures outside this range please contact Rotork. Prior to installation actuators should be stored in a dry location with a temperature range not exceeding -60° to 80°C (-76°F to 176°F).

Actuator Type	Standard Temperature*	Low temperature option*
IQ, IQM	-30°C to +70°C (-22°F to +158°F)	-50°C to +40°C (-58°F to +104°F)
IQS, IQD, IQH	-20°C to +70°C (-4°F to +158°F) only	NA
IQT / IQM / IQTF	-30°C to +70°C (-22°F to +158°F)	-50°C to +40°C (-58°F to +104°F)

*Hazardous Area certification determines permissible operating temperature range. Refer to 6.

6 Non-Hazardous & Hazardous Certified Enclosures

All IQ actuator hazardous and non-hazardous area enclosures are watertight to IP68/NEMA 4 & 6. Through the use of non-intrusive commissioning and adjustment using the supplied infra-red IQ Setting Tool, covers never need removing and therefore the hermetic, factory-sealed enclosure protects internal components for life. The terminal compartment is sealed from other areas by the Rotork double seal, maintaining watertight integrity even during site connection.

In addition, the IQ Setting Tool is certified Intrinsically Safe permitting power-on commissioning in hazardous areas.

Actuators are available with the following enclosure types for which the ambient working temperature ranges are stated. Where option temperatures are indicated, changes to some actuator components are required and therefore the temperature requirement must be specified. Hazardous area approvals for other country standards are available; please contact Rotork.

Standard specifications

The IQ and IQT range are available built in accordance with the following standards:

6.1 Non-Hazardous Area Enclosures

WT: Standard Watertight

Standard	Rating	Standard temperature	Option 1	Option 2
IEC 60529 (1989-11)	IP68 – 7metres / 72 Hrs	-30°C to +70°C	-40°C to +70°C	-50°C to +40°C
BS EN 60529 (1992)	IP68 – 7metres / 72 Hrs	-30°C to +70°C	-40°C to +70°C	-50°C to +40°C
NEMA (US)	4 & 6	-22°F to +158°F	-40°F to +158°F	-58°F to +104°F
CSA (Canadian)	4 & 4X	-22°F to +158°F	-40°F to +158°F	-58°F to +104°F
Applicable actuator ranges and temperature limitations	ALL	IQS, IQD, IQH, IQT failsafe -20°C to +70°C only (-4°F to +158°F)		

6.2 Hazardous Area Enclosures

European Hazardous Area Directive - ATEX

Directive Code	Enclosure Code	Standard temperature	Temperature Option 1	Temperature Option 2	Temperature Option 3
ATEX II 2GD	Exd IIB T4 Exd IIC T4	-20°C to +70°C (-4°F to +158°F)	-30°C to +70°C (-22°F to +158°F)	-40°C to +70°C (-40°F to +158°F)	-50°C to +40°C (-58°F to +104°F)
ATEX II 2GD	Exde IIB T4 Exde IIC T4	-20°C to +70°C (-4°F to +158°F)	-30°C to +70°C (-22°F to +158°F)	-40°C to +70°C (-40°F to +158°F)	-50°C to +40°C (-58°F to +104°F)
Applicable actuator ranges and temperature limitations	ALL except IQT failsafe type 1	IQS, IQD, IQH, -20°C to +70°C (-4°F to +158°F) only			

International Hazardous Area - IECEx

	Enclosure Code	Standard temperature	Temperature Option 1	Temperature Option 2	Temperature Option 3
	Exd IIB T4 Exd IIC T4	-20°C to +60°C (-4°F to +140°F)	-30°C to +60°C (-22°F to +140°F)	-40°C to +60°C (-40°F to +140°F)	-50°C to +40°C (-58°F to +104°F)
	Exde IIB T4 Exde IIC T4	-20°C to +60°C (-4°F to +140°F)	-30°C to +60°C (-22°F to +140°F)	-40°C to +60°C (-40°F to +140°F)	-50°C to +40°C (-58°F to +104°F)
Applicable actuator ranges and temperature limitations	ALL except IQT failsafe type 1	IQS, IQD, IQH, -20°C to +60°C (-4°F to +140°F) only			

Standard specifications

6.2 Hazardous Area Enclosures cont.

USA Hazardous Area – Factory Mutual Certified Explosionproof to FM3615.

Class	Division	Groups	Standard temperature	Option 1	Option 2	Option 3
I II	1 1	C, D E, F, G	-22°F to +140°F (-30°C to +60°C)	-40°F to +40°F (-40°C to + 60°C)	-58°F to +104°F (-50°C to +40°C)	X
I II	1 1	B, C, D E, F, G	-22°F to +140°F (-30°C to +60°C)	-40°F to +40°F (-40°C to + 60°C)	-58°F to +104°F (-50°C to +40°C)	X
Applicable actuator ranges and temperature limitations		ALL except IQT failsafe type 1	IQS, IQD, IQH, -20°C to +60°C (-4°F to +140°F) only			

Canadian Hazardous Area – Canadian Standards Association (CSA EP) to C22.2 No 30-M

Class	Division	Groups	Standard temperature	Option 1	Option 2	Option 3
I II	1 1	C, D E, F, G	-22°F to +140°F (-30°C to +60°C)	-58°F to +104°F (-50°C to +40°C).	X	X
I II	1 1	B, C, D E, F, G	-22°F to +140°F (-30°C to +60°C)	-58°F to +104°F (-50°C to +40°C).	X	X
Applicable actuator ranges and temperature limitations		ALL except IQT failsafe type 1	IQS, IQD, IQH, -20°C to +60°C (-4°F to +140°F) only			

IQ Pro Setting Tool Certification

Directive / Standard	Rating	Standard temperature
ATEX II 1G	EExia IIC T4	-30°C to +50°C (-22°F to +122°F)
FM3610	Intrinsically Safe Class I, Div 1 groups A,B,C,D: T4	-30°C to +50°C (-22°F to +122°F)
Canada CSA – C22.2 No.157-92	Exia - Intrinsically Safe Class I, Div 1 groups A,B,C,D: T4	-30°C to +50°C (-22°F to +122°F)

7 Regulatory Standards

Compliance with the following European Economic Community Directives permits the IQ *Pro* and IQT *Pro* range actuators to be CE marked under the provision of the Machinery Directive.

Directive	Applicable to	Reference
Electromagnetic compatibility (EMC)	Immunity to/emissions of electromagnetic energy	89/336/EEC as amended by 92/31/EEC
Low voltage (LV)	Electrical Safety	73/23/EEC amended by 93/68/EEC by the application of EN 60204-1 1993
Machinery*	Product safety	Actuators follow the provision of the Machinery Directive (89/392/EEC) as amended by 91/368/EEC and 93/44/EEC. The IQ must not be put into service until the equipment into which it is being incorporated has been declared to be in conformity with the provisions of the European Community Machinery Directive (89/392/EEC) 91/368/EEC and 93/44/EEC*
Waste Electrical Equipment (WEE)	Exempt under the scope of the directive	

*Actuators are not classified as machines within the scope of the machinery directive.
Contact Rotork for a copy of our Declaration of Conformity and Incorporation



Standard specifications

8 Power, Control & Indication

8.1 Power Supplies

IQ and IQT actuators are suitable for operation with the following single, three phase - three wire and DC power supplies:

Supply voltage ranges – Actuator availability

Standard Voltages	Phase	IQ10 to IQ70 & IQ95	IQ90 & IQ91	IQM IQML	IQS	IQD10	IQD12 IQD18	IQD20 IQD25	IQT IQTM
24	DC	X	X	X	X	✓	X	X	✓
48	DC	X	X	X	X	✓	✓	X	X
110	DC	X	X	X	X	✓	✓	✓	X
100,110,115,120	1	X	X	X	✓	X	X	X	✓
208,220,230,240	1	X	X	X	✓	X	X	X	✓
200,208,220,230,240	3	✓	X**	✓**	X	X	X	X	✓*
380,400,415,440,460,480	3	✓	✓**	✓	X	X	X	X	✓*
500,550,575,590	3	✓	✓	X	X	X	X	X	✓*
600,660,690	3	✓	✓	X	X	X	X	X	✓*

Voltage tolerance	+/-10%	Applies for rated torque performance; duty cycle and speed is not guaranteed
Frequency tolerance	+/-5%	Applies for rated torque performance; duty cycle and speed is not guaranteed
Max. starting volt drop	-15%	Actuators capable of starting and running up to speed
Non standard tolerances	Larger volt drops / frequency variations than those quoted can be catered for but may affect actuator selection / sizing. Contact Rotork	
Uninterruptible Power Supply systems	For AC systems, UPS systems should conform to recognised supply standards such as EN60160 in respect of waveform, spikes, harmonics etc. The tolerances above should not be exceeded.	

* IQT/IQTM ranges - 3 phase supplies

The IQT utilises 2 phases only. A parking terminal for phase 3 is available for systems where all 3 phases are distributed. For multiple actuators, even diversity over all three phases should be considered.

** Limited availability

IQ91 not available at 380V 60Hz. IQ90 has limited availability at voltages up to 240V.
IQM/IQML35 not available at voltages below 380V.

Reference documents

For operating electrical consumption data refer to E130E (IQ ranges), E135E (IQT ranges) and E430E (IQM ranges) available to download at www.rotork.com

Standard specifications

8.2 Local Control, Indication & Set-up

Non-intrusive selectors are provided on the actuator electrical control cover which also includes a window showing actuator position, status and alarm display.

The control cover may be rotated through 360° (90° increments) to suit actuator orientation/operator access. Set-up is over an infra-red interface using the supplied setting tool.

Standard local controls

Operation	Type	Function	Comments
Control mode	Red, rotary selector	Selects "Local", "Stop" or "Remote" control	Can be padlocked in each position (stop remains available) for site operational protection
Local control	Black, rotary selector	Initiates local "Open" and "Close" operation	Spring return to centre neutral position. Local control may be user configured for inching action
Infra-red	IQ Pro Setting Tool	Initiates local "Open" and "Close" operation	May be user configured for I-R operation over a nominal distance of 0.5m (1.5')

Standard local indication

Operation	Type	Function	Comments
Position indication	LCD - Large character (16mm/0.6")	Open / close icons + 0-99% in 1% increments	Back-lit (power on) – operating temperature range -50°C to +70°C (-58°F to +158°F) Battery supported power off
Position indication	Coloured indication lights	Green (close), Red (open), Yellow (mid-travel)	Power-on lamp indication, colours can be reversed
Status and Alarm	LCD – text display 2 x 16 characters	Real time valve & actuator status and alarm text messages	Power on –battery supported (when awake) Multilingual-English plus 1 option: E, D, Fr, Ru. Single Chinese available (Mandarin).
Status and Alarm	General alarm icon Battery alarm icon	Warning triangle Battery icon	Power on & off indication of active alarm Power on & off indication of low battery
Status and Alarm	Help screens	8 real time help screens (icon + text)	Complimentary to status / alarm text display

Standard specifications

8.2 Local Control, Indication & Set-up cont.

Actuator Set-Up, Configuration & Datalogging

Setting Tool LCD displays

Simple non-intrusive, interactive set-up procedure using supplied Infra red setting tool with read-back from LCD's. Settings include limits & torque switching, indication contacts and control options. Settings may be password protected. Setting tools are provided on a 1 for 10 actuators basis

PC/PDA

Using freeware IQ-Insight, actuators may be configured / analysed over IrDA™ interface

Datalogging

Standard onboard datalogger provides valve torque and starts profiles, operational statistics, events log. Actuator configuration & manufacturing data also available. Files can be downloaded direct to PC or to IQ Pro Setting Tool (IS certified) for transport to office PC. Freeware IQ Insight for PC is available to download at www.rotork.com

Options

Vandal resistant

Option 1:
red/black control selectors
not fitted

Option 2:
red/black control selectors
not fitted + lockable
window cover

Option 3:
Stainless steel lockable cover
protects standard selectors
and window

Reference documents

Refer to E170E3 (IQ Pro) / E175E3 (IQT Pro) for details of status and alarm text messages, alarm icons, help screens and actuator set up procedure. Refer to E117E for Setting Tool Pro / IQ insight details



Standard specifications

8.3 Remote Control & Indication

IQ Pro and IQT Pro range actuators enable remote control and indication of valves for centralised control. Actuator control and indication forms are available to meet the requirements of the various site control systems, from simple manual pushbutton control through to sophisticated distributed control systems (“DCS”) using relay outputs or digital “bus” network systems.

Standard remote controls

Operation	Type	Range	Comments
Open/Close/Stop Common	Positive switched 3 x Opto-isolated inputs designed for fleeting or maintained contacts	20-60V AC/DC, 120V AC, 5mA per input (12mA at 120V AC)	Actuator derived - 24V DC (120V AC available as an option) or externally supplied derived from the control system. Various forms available
ESD Open interlock Close interlock Common	Positive switched 3 x Opto-isolated inputs designed for maintained contacts.	20-60V AC/DC, 120V AC, 5mA per input. (12mA at 120V AC)	ESD can be user configured open, stayput or close, from a NO or NC contact. ESD has priority over all other applied local or remote control signals. Interlocks provide hardwired “permissive” protection (ie. main and bypass control) and are active for local and remote or may be configured for remote signals only

Options

120V AC actuator derived supply	15VA rated	Actuator derived supply for remote control
125V DC remote control	20mA per input	Suitable for 125V DC remote control supply – positive switching
Negative switching	20-60V AC/DC, 120V AC - 5mA per input (12mA at 120V AC)	Suitable for Negative switched systems applies to Open, Stop, Close, ESD and Interlocks
Analogue control – Option Folomatic	0 to 5/10/20/mA or volt ranges	Proportional control over the whole or part of valve stroke. Configurable for open, close or stayput on loss of analogue signal
Hydraulic shock “water hammer”/surge protection – Option Interrupter timer	Internal control system	Pulsed operation with independently adjustable on and off time periods in the range 1-99 seconds can be selected to operate over any portion of the closing or opening valve stroke, effectively reducing valve speed.

Standard specifications

8.3 Remote Control & Indication cont.

Standard remote indication

Operation	Type	Range	Comments
Position, status and alarm indication	4 x Configurable volt free latching contacts - S1 to S4. Single pole -single throw (SPST), configurable NO or NC.	5mA to 5A, 120V AC, 30V DC	Independently configurable using the supplied IQ Setting Tool to signal one of the following: Valve Position: fully open, fully closed or intermediate positions (0-99% open) Status: Valve opening, closing, moving, Local stop selected, local selected, remote selected, open or close interlock active, ESD active Valve Alarms: Torque tripped in mid travel, going open, going closed, valve jammed, handwheel operation Actuator alarms: Lost phase (3 phase IQ only), customer 24V dc (120V AC) supply lost, battery low, internal failure detected, thermostat tripped
Actuator availability	Monitor Relay - Non configurable relay - change over contact	5mA to 5A, 120V AC, 30V DC	The relay will de-energise when the actuator is un-available for remote control due to any one or more of the following conditions: Power supply or control supply lost; local control selected; local stop selected; motor thermostat tripped; detected internal failure

Options

Operation	Type	Range	Comments
Position, status and alarm indication	4 x Configurable volt free latching contacts – S5 to S8. Single pole – change over (SPCO)	5mA to 5A, 120V AC, 30V DC	Independently configurable using the supplied IQ Setting as per contacts S1 to S4 above
Analogue position feedback	Current position transmitter - CPT	4-20mA output proportional to position	Auto range to set limits. Normally internally powered, available suitable for externally "loop" powered (will default to 4mA when actuator is powered down).
Analogue torque feedback	Current torque transmitter - CTT	4-20mA output proportional to output torque	Range 0% to 120% of rated torque (4 to 20mA)
Auxiliary power supply	Maintains power to the actuator control on loss of mains	Nominal 24V DC, 1A (switching inrush 8A max)	Customer supply maintains backlit display, CPT analogue indication and bus network communications during actuator power outages. Customer supply is isolated from internal control power for protection

Reference documents

Refer to E120E - IQ Control and Monitoring

8.4 Fieldbus System Control Options

IQ *Pro* and IQT *Pro* range actuators are available with the following network interface cards to enable remote control and indication using digital “bus” network systems communication to the control systems (“DCS”).

Standard remote controls

Network Type	Comments
Pakscan	An internally mounted Pakscan field unit for remote control and status indication over a fault tolerant two wire serial link. Loop distances of up to 20 km without repeaters and host communications using Modbus protocol. System variables programmable over the infra-red data link. For more information please refer to publication S000E
Modbus	Modbus modules suitable for single or dual communication highways may be included in the IQ and IQT actuator, to provide Fieldbus communication of all the actuator control functions and feedback data. Data is carried on an RS485 data highway and the communications protocol used is Modbus RTU. System variables such as unit address and data baud rate are programmed over the infra-red data link. For more information please refer to publication S117E
Profibus	A Profibus DP interface module is available to allow the actuator to be integrated into a Profibus network. Full compatibility with EN 50170 is provided and the Profibus network allows full actuator control and feedback of data to the host. For more information please refer to publication S113E
Foundation Fieldbus	An IEC 61158-2 compliant Foundation interface module allows the actuator to be connected to a Foundation network. The device has link scheduler capability as well as digital and analogue function block capability. Foundation Fieldbus actuators can communicate directly between themselves without the need of a host supervisory system. For more information please refer to publication S114E
DeviceNet	The ODVA certified DeviceNet interface module, with full status data feedback and actuator digital and analogue control, connects directly to the popular DeviceNet data highway. Data feedback includes both torque and high accuracy position information, while the inbuilt positioner allows for full modulating control. Up to 63 IQ actuators can be connected on a single DeviceNet highway. For further information refer to publication S116E

8.5 Functional Safety - Safety Integrity Level Applications

IQ *Pro* and IQT *Pro* are TÜV certified for applications requiring functional safety to SIL 2 (or SIL 3 with a 1oo2 valve actuator configuration) as per standard IEC61508 with the addition of the Safety Function Control Module (SFCM) option.

Safety Function	Available actuator ranges	Power supply	Base wiring diagram	Plus 4-20mA analogue position indication
Stayput	IQ (3-phase only) IQT / IQTF IQTM	3-phase 1, 3-phase & DC 1, 3-phase & DC	3000S000 6000S000 7000S000	3000S000 6000S000 7000S000
ESD	IQ (3-phase only)	3 phase	3000S000	3000S000

Restrictions

No other actuator types or control / indication options are available within the scope of the TÜV approval certificate. To achieve the requirements under which approval by TÜV was granted, actuators must be installed, commissioned, operated and maintained in accordance with the safety manual E173E3.

Reference documents

IQ *Pro* -Option SFCM Actuator Safety Manual - publication E173E3

Standard specifications

9 Protection & Operating Features

The IQ Pro and IQT Pro control system incorporates the following standard operating features and comprehensive valve, actuator and control protection to ensure reliable valve operation and protection under all circumstances.

Fault / Feature	Cause / Operation	Function
Obstructed valve	Valve meets an obstruction or process conditions that prevent movement. Obstruction must be sensed and operation prevented to prevent damage to valve and actuator	Independent Settable Open and Close Torque Switches Torque switch will "torque trip" the actuator motor when the preset output torque level is reached. Torque switches can be set in the range 40% to 100% of rated torque. Torque trips are indicated on the actuator display and can be remotely signalled
Jammed valve	Seated valve is stuck in its seat - often after long periods of inactivity	Jammed Valve Protection The motor is de-energized if no output movement occurs after a (nominal) 3 seconds from receipt of a signal to open or close. This prevents the actuator motor stalling for long periods and possible burn out. Torque trips are indicated on the actuator display and can be remotely signalled
Torque switch bypass	Provides increased torque above actuator rated for unseating sticky valves	Torque Switch By-pass User selectable – secondary setting "At". Torque switches are automatically bypassed during the first 5% of travel from both open and close limit positions. This permits torque above actuator rated torque and up to actuator stall torque (1.4 to 2.4 times rated torque) to be developed during unseating, ensuring "sticky" valves do not cause unwanted torque trips. Refer also to Jammed Valve Protection
Torque switch hammer	Actuator repeatedly tries to move an obstructed valve in response to a standing control signal. This can cause damage to both valve and actuator	Anti Hammer Protection Once a torque trip occurs the control prevents repeated operation in the same direction as a response to a standing remote or local control signal. Actuator must be operated in the opposite direction and therefore moved away from the obstruction, which then has chance to clear, before it can be signalled to run in the requested direction. Torque trips are indicated on the actuator display and can be remotely signalled
Incorrect phase rotation (3 phase actuators only)	Due to 3-phase supply wiring incorrectly connected to actuator. Actuator moves in the opposite direction to that signalled. At end of travel the wrong limit/torque switch is activated preventing the motor being de-energised and causing it to stall with consequent valve damage and/or motor burn out.	Syncrophase™ Protection ensures actuator always runs in the correct direction corresponding to the applied control signal (open or close). The patented circuit senses connected phase rotation and ensures the actuator always runs in the correct direction by energising the appropriate motor control contactors/switches
Lost Phase / Motor overheating (3 phase actuators only)	"single phasing" one of the 3 phases applied to the actuator is lost due to fault causing the motor to single phase i.e. attempts to run with only 2 of the 3 phases applied. Motor may fail to start (stall) or run unbalanced causing overheating and possible burnout	Syncrophase™ The patented circuit monitors all three supply phases. If a phase is lost the Syncrophase circuit prevents the motor from being energised. If during operation one phase is lost this cannot be detected due to back-feed through the motor windings, however once operation stops, re-energising of the motor will be prevented. Lost phase is indicated on the actuator display and can be remotely signalled
Motor overheating	Actuator duty cycle is exceeded causing the motor to overheat. This often occurs during factory acceptance testing /commissioning or during process start up	Motor Thermostat Protection Two thermostats are embedded in the motor end windings (hottest part of the motor) which directly sense motor temperature. Thermostats will open circuit when set temperature is reached causing the motor to be de-energised. Thermostats will auto-reset once the motor has cooled sufficiently allowing operation to continue. Motor Thermostat trips are indicated on the actuator display and can be remotely signalled

Fault / Feature	Cause / Operation	Function
Instantaneous reversal	Control system instantaneously reverses the control signal which causes the actuator to reverse direction with associated inertial stress to valve drive and internal motor switching surges	Instantaneous Reversal Protection A delay of 300ms is automatically applied between reversals allowing the actuator to come to rest before responding to reverse control signal
Actuator fault	Control system instantaneously	ASTD (automatic self test & diagnosis) ASTD detects any internal control system failures preventing operation. Detected internal control system faults are indicated on the actuator display allowing rapid diagnosis and can be remotely signalled. In addition help screens can be accessed allowing problem to be pin-pointed
Remote control circuit failure (actuator derived remote control supply only)	Loss of remote control	The 24V DC internal power supply made available for remote control switching is protected by an auto-reset fuse device. Should the power drawn from the supply exceed its rating (due to a remote control wiring fault, etc.), the fuse will disconnect the supply. Once the fault is cleared the supply will automatically be reinstated. Loss of internal supply is indicated on the actuator display and can be remotely signalled
Spurious operation	Operation commanded due to unintended or spurious remote control signals leading to process problems or hazards	Conditional Control User selectable – secondary settings A8 and A9. The interlock input can be configured for “conditional control”, being active only for remote control. In this mode, for the actuator to respond to a remote control signal, two signals must be applied simultaneously, one to the control input and one to the interlock input. If an unintended or spurious signal is applied only to the control input it will be ignored. Intended signals can therefore be verified by applying a second “permissive” signal, effectively preventing spurious operation. In addition the TÜV approved SFCM option is available for SIL 2 applications requiring safety function “stayput”. Refer to E173E3.
Emergency Shut Down ESD	Priority action where the valve is required to stayput or move to a safe end of travel position determined by the process (open or closed limit)	Dedicated ESD Control Input User configurable secondary settings A1 to A5 ESD action has priority over any existing or applied local or remote control signal. ESD can be configured to open, close or stayput depending on the process requirements. It must be derived from a stayput type, normally open or normally close ESD contact (configurable) and may be configured to override local stop, interlocks or interrupter timer. For IQ 3-phase units only, the TÜV approved SFCM option is available for SIL 2 applications requiring safety function “ESD”. Refer to E173E3.

Standard specifications

10 Components

Details of major actuator mechanical and electrical/electronic components are provided below.

10.1 Handwheel

A handwheel is provided to allow manual operation of the valve during electrical power interruption. Handwheel size and mechanical advantage are generally designed in accordance with standards

EN 12570 and AWWA C540 (American Water Works Association) to give the most efficient compromise of force and turns for emergency operation.

Handwheel turns:

Actuator Range	Actuator Size	Standard Ratio / Turns	Option 1	Option 2
IQ Pro	IQ10, IQ12, IQ18	1:1 (Direct)	12:1	X
IQ Pro	IQ20, IQ25	1:1 (Direct)	13.5:1	X
IQ Pro	IQ35	1:1 (Direct)	22.5:1	X
IQ Pro	IQ40	1:1 (Direct)	15:1	30:1
IQ Pro	IQ70, IQ91	15:1	30:1	X
IQ Pro	IQ90, IQ95	15:1	45:1	X
IQT Pro	IQT125, IQT250, IQT500	80 turns/90°	X	X
IQT Pro	IQT1000, IQT2000	86 turns/90°	X	X

During electric operation of the actuator, the handwheel is mechanically disengaged from the drive. To engage handwheel operation, the hand/auto selection lever is pushed down and released after which handwheel operation remains selected. When electrical operation takes place the actuator will automatically return to motor drive without lever or handwheel kickback.

The hand/auto selection lever incorporates a facility for locking in the hand or auto positions using a 6mm diameter hasp padlock (not supplied by Rotork), preventing engagement of motor drive (locked in hand) or engagement of handwheel drive (locked in auto). Emergency disengagement of motor drive can be selected by pushing down and holding the hand/auto lever during electric operation.



Standard specifications

10.2 Lubrication

IQ and IQT actuators are factory filled for life with premium quality gear oil selected for the application. Standard oils are automotive grades easily available worldwide and have been used successfully for over 40 years. Oil lubrication outperforms grease over a wide temperature range and allows installation in any orientation. It has none of the problems

associated with grease such as separation at elevated temperatures and “tunnelling” at lower temperatures where grease is thrown away from rotating components creating a void or tunnel in the grease around components that require lubrication.

Lubrication

Range	Standard Oil	Standard Temp range	Option Low temp -50°C to +40°C (-58°F to +104°F).	Option Food Grade -10°C to +70°C (-14°F to +158°F).
IQ Pro	SAE80EP	-30°C to +70°C (-22°F to +158°F).	MOBIL SHC624	Hydra Lube GB Heavy
IQT Pro	TEXACO 9330 +25% Kerosene	-30°C to +70°C (-22°F to +158°F).	TEXACO 9330 +75% BP SHF LT15	Hydra Lube GB Medium

Food grade

Lubricant is a synthetic, non-aromatic hydrocarbon mixture with PTFE and other additives. It does not contain chlorinated solvents. Food grade grease used in assembly and thrust bearings is Hydra Lube WIG Medium-NLGI-123.

10.3 Finish

All IQ and IQT actuator finishes are tested in accordance with Rotork 1,000 hour Cyclic salt spray test procedure which is the most realistic and arduous test cycle applicable. The test combines cyclic salt spray, drying and humidity at elevated temperatures on complete factory built actuators. This tests the finish and the various substrate materials, fixings and

interfaces that make up an actuator. Substrate materials and finishes are selected to provide maximum corrosion resistance combined with good adhesion. For full specification of paint finishes refer to publication E151E.

Finish

Range	Size	Standard Finish	Offshore finish
IQ Pro	IQ10 to IQ35	polyester powder coating, silver grey	2 pack epoxy coatings
IQ Pro	IQ40 to IQ95	Air-dried urethane reinforced synthetic alkyd. silver grey	2 pack epoxy coatings
IQT Pro	IQT125 to IQT2000	polyester powder coating, silver grey	2 pack epoxy coatings

Project specific finishes / colours can be catered for. Apply to Rotork.

Standard specifications

10.4 Motor

IQ *Pro* and IQT *Pro* actuators utilise purpose designed motors integral to the actuator. As such motors do not fall within the scope of IEC 60034- MG1, however do meet the applicable requirements, where pertinent, to motor design for actuator operation.

Actuator Type	Duty Classification	Comments
IQ	On-Off & Inching	Class F insulated, 3-phase squirrel cage motor incorporating thermostat protection. Low inertia design. Nominal 60 Starts per hour at a rate not exceeding 200 starts per hour, 15 minutes rated based on a nominal torque of 33% of rated. Class H available as an option where hazardous area certification does not limit temperature rise to "T4" 135°C.
IQS	On-Off & Inching	Class F insulated, single phase capacitor / run start squirrel cage motor incorporating thermostat protection. Low inertia design. Nominal 60 Starts at a rate not exceeding 200 starts per hour per hour, 15 minutes rated based on a nominal torque of 33% of rated. Class H available as an option where hazardous area certification does not limit temperature rise to "T4" 135°C.
IQD	On-Off & Inching	Class F insulated, permanent DC brush motor incorporating permanent magnet DC brush motor incorporating thermostat protection. Nominal 60 Starts per hour at a rate not exceeding 200 starts per hour, 15 minutes rated based on a nominal torque of 33% of rated.
IQM	Modulating	Class F insulated, 3-phase squirrel cage motor incorporating thermostat protection. User selectable thyristor controlled dynamic braking available. Low inertia design. 1,200 starts per hour, 50% duty cycled based on a modulating torque of 50% of rated torque. Class H available as an option where hazardous area certification does not limit temperature rise to "T4" 135°C.
IQT / IQTF	On-Off & Inching	Permanent magnet 24V DC motor (DC supply derived internally from 3 and single phase supplies) incorporating thermostat protection. Low inertia design. Nominal 60 Starts at a rate not exceeding 200 starts per hour, 15 minutes rated based on a nominal torque of 75% of rated.
IQTM	Modulating	Permanent magnet 24V DC motor (DC supply derived internally from 3 and single phase supplies) incorporating thermostat protection. Low inertia design. Nominal 1,200 starts per hour, 50% duty cycled based on a modulating torque of 50% of rated torque.

Reference documents

IQ / IQS / IQD Motor data publication E130E

IQM / Motor data publication E430E

IQT / IQTF / IQTM Motor data publication E135E

Standard specifications

10.5 Power Module

The power module for IQ *Pro* and IQT *Pro* actuators produces internal power supplies for control systems and remote control derived from the actuator electrical supply. It also contains the motor control and switching components.

Actuator Type	Internal power supplies	Motor switching
IQ	Split bobbin transformer producing control circuits, option card supplies and supply for 24V DC actuator fed remote control (120V AC option).	Reversing contactor assembly, mechanically and electrically interlocked. 24V DC coil up to and including size IQ35 and 120V AC for IQ40 and above.
IQD	DC-DC converter isolates the DC actuator supply from internal supplies for control and 24V DC supply for actuator fed remote control. Fuse protected. Incorporates sleep circuit for power reduction when used on solar powered derived DC supplies.	Reversing contactor assembly, mechanically and electrically interlocked. 24V DC coil supply.
IQS	Split bobbin transformer producing control circuits, option card supplies and supply for 24V DC actuator fed remote control (120V AC option). Fuse protected.	Solid state thyristor array for motor switching / reversal and capacitor starting. Includes snubber protection and timing control.
IQM	Split bobbin transformer producing control circuits, option card supplies and supply for 24V DC actuator fed remote control. Fuse protected.	Solid state thyristor array for motor switching / reversal and braking (user selectable). Includes snubber protection and timing control.
IQT / IQTF / IQTM	Split bobbin transformer producing control circuits, option card supplies and supply for 24V DC actuator fed remote control (120V AC option). Fuse protected.	Torroidal power transformer / rectifier deriving DC motor power supply from AC actuator supply - fuse protected. Solid state motor switching incorporating motor speed control.
IQT / IQTF / IQTM 24V DC actuator power supply only	DC-DC converter isolates the DC actuator supply from internal supplies for control and 24V DC supply for actuator fed remote control. Fuse protected.	Rectifier and fuse protection ensures correct polarity and protection of supply. Solid state motor switching incorporating motor speed control.

10.6 Torque Sensor

State of the art piezo thrust sensor measures motor shaft thrust produced as a reaction to output torque developed in the motor worm and wheel gear assembly. Thrust measured is directly proportional to output torque. The piezo sensor develops a voltage proportional to shaft thrust (output torque) which is amplified and then measured by the control module. Output torque is controlled by switching the motor off when the set torque limits have been reached. This system allows the torque to be displayed via the LCD display and captured by the datalogger in the form of valve torque profiles, statistical torque information and the event log.

10.7 Position Sensor

Contact-less hall effect sensors measure actuator output shaft angular rotation to a resolution of 7.5° (15° max for reversal). Sensors are direction sensitive producing a phased digital pulse width modulated signal. The control module counts the pulses and compares these to the set limit range. Precise position control is then available for limit switching, position indication and data logging. The position sensor is very simple with only one moving component and has a proven, reliable track record in use with IQ actuators for over 15 years.



Standard specifications

10.8 Control Module

The control module for IQ *Pro* and IQT *Pro* actuators is common and takes the form of a PCB with on-board liquid crystal displays (LCD) For IQM and IQTM actuators the control module incorporates “fast remote” control components (24V DC remote control only) allowing rapid actuator switching down to 20 ms pulses for precise positioning.

Logic controlled, the control module is programmed over the non-intrusive Infra-red interface with set-up configuration for torque, limits indication and control features undertaken using the supplied IQ *Pro* Setting tool. It monitors local and remote control signals, torque and position to switch the actuator motor in the correct direction or off.

Standard control features are shown below:

Feature	Type	Specification
Remote control	Input	User switched Open/Close/Stop/ESD and interlock signals. Opto-isolated inputs for protection.
Local control	Input	Open/Close/Stop and Local/Remote selection. Non intrusive control switches are magnetically operated so there is no penetration of covers.
Position IQ <i>Pro</i> range	Input	Digital signal derived by position sensor. Resolution to 7.5° of output rotation. Limit range configurable between 2.5 and 100,000 output turns.
Position IQT <i>Pro</i> range	Input	Digital signal derived by position sensor. Angular resolution to 0.1° Minimum Limit setting range is 10°. Maximum range will be limited by mechanical stops (nominally 95°). The IQTF actuator limits can be configured up to 50 turns nominal. Position sensing is battery backed up for operation when the main electrical supply to the actuator is switched off. Power off local and remote (contacts S1 – S4) position indication and updating is enabled using a standard battery located in a separate compartment.
Torque - IQ <i>Pro</i>	Input	The piezo thrust sensor directly measures output torque and converts value to a voltage signal. Torque can be set in the range 40% to 100% of rated torque with the additional facility to bypass torque switching
Torque - IQT <i>Pro</i>	Input	Torque signal derived from DC motor current which is directly proportional to torque. Torque can be set in the range 40% to 100% of rated torque with the additional facility to bypass torque switching
Set-up	Input	Set-up over the Infra red interface allows all settings to be configured for valve and process requirements. Set-up is non-intrusive requiring no covers be removed using the supplied IQ <i>Pro</i> Setting Tool. All settings can be password protected.
Indication contacts	Output	Four volt free contacts S1 to S4 can be configured for a variety of position, status and alarm indication for remote indication and monitoring
LCD Indication	Output	The on board backlit LCD display presents position, torque and set up displays for configuration. The LCD display is divided into 2 parts providing a large position indication (Open/Close icons plus % readout in 1% increments for mid travel) and a multilingual text display providing status, alarm and set up information.
Datalogger	Output	The control module includes a datalogger which stores torque, position and operational data in non volatile memory for download via IrDA™ to the supplied setting tool or notebook PC. Data is date/time stamped. Datalogger can be analysed using freeware IQ insight for PC.
Memory	System	All configured settings are stored in non volatile EEPROM memory (does not require power).
Micro-controller	System	Provides all control function logic, set up programming and allied system requirements. Software is field upgradeable for future enhancements. The micro-controller is widely used in the automotive industry with a long track record and a very reliable history.

Standard specifications

10.9 Conduit / Cable Entries

IQ *Pro* and IQT *Pro* gearcases are machined with conduit/cable entries as indicated below. Unless otherwise specified IQ *Pro* range actuators are despatched with adapter 1 fitted into the gearcase entry. Unless otherwise specified IQT *Pro*

range actuators are despatched with no adapters fitted. Alternative adapters are available. Number of entries required and adapter type must be specified with order.

Actuator Type	Gearcase Entries	Adapter 1	Adaptor 2
IQ <i>Pro</i>	1 x 1.5" plus 2 x 1" ASA NPT	1 x M40 plus 2 x M25	1 x PG29 and 2 x PG16
IQ <i>Pro</i> option	Additional 1 x 1"	Additional 1 x M25	Additional 1 x PG16
IQT <i>Pro</i>	2 x M25	2 x ASA NPT 1"	2 x PG16
IQT <i>Pro</i> option*	Additional 2 x M25	Additional 2 x ASA NPT 1"	Additional 2 x PG16

IQ *Pro* and IQT *Pro* actuators are despatched with transit plugs fitted into the conduit entries. It is the responsibility of the installer to ensure the appropriate cable/conduit adapters, cable glands and/or blanking plugs are fitted in order to maintain hazardous area certification and ingress protection levels. Certified adapters and blanking plugs are available as optional extras.

* IQT *Pro* actuators supplied with Pakscan, FieldBus, ProfiBus, ModBus or DeviceNet interface option cards will be supplied with the optional entries provided (4 entries in total).

10.10 Terminals

The terminal compartment for IQ *Pro* and IQT *Pro* actuators takes the form of a separately sealed compartment containing segregated metric thread M5 power and M4 control terminals. Terminal screws and washers are supplied with the actuator. Terminals are designed to accept ring tag crimped field wiring conductors up to 16mm² for power and 4mm² for control/indication. The terminal compartment cover carries a terminal identification code card. Each actuator is despatched with the applicable Installation and Maintenance Manual, actuator wiring diagram and remote control connection schematic.

10.11 Wiring

IQ *Pro* and IQT *Pro* actuators utilise jig built wiring harnesses of individually numbered, tropical grade PVC insulated, stranded conductors. All internal control connections to the printed circuit boards use unique or polarised plugs and sockets.

10.12 Battery

When power to the actuator is isolated, all settings are retained in an EEPROM. In the event of manual operation of the valve during isolation or loss of the power supply a battery provides power to the position-sensor and control module to update the valve position. The battery also powers the LCD display, without backlighting, and the four latching contacts S1-S4 while the power to the actuator is not available. Infra-red set up is also available with main power off.

Based on experience gained over 15 years of typical applications, the expected battery life is around 5 years. Battery life is however subject to temperature and at elevated temperatures may be reduced. Actuators can operate perfectly well without a battery, however if operated by handwheel without power the control module cannot update with the new position when power is restored. Limits should therefore be reset.



A full listing of our worldwide sales and service network is available on our website.

UK
Rotork plc
tel +44 (0)1225 733200
fax +44 (0)1225 333467
email mail@rotork.co.uk

USA
Rotork Controls Inc.
tel +1 (585) 247 2304
fax +1 (585) 247 2308
email info@rotork.com

Controls

Electric Actuators and Control Systems

Fluid Systems

Fluid Power Actuators and Control Systems

Gears

Gearboxes and Gear Operators

Site Services

Projects, Services and Retrofit

www.rotork.com

As part of a process of on-going product development, Rotork reserves the right to amend and change specifications without prior notice. Published data may be subject to change. For the very latest version release, visit our website at www.rotork.com

The name Rotork is a registered trademark. Rotork recognises all registered trademarks. Published and produced in the UK by Rotork Controls Limited. POWTG0809